



ITT

Engineered for life

Enidine / Conoflow
105 Commerce Way
Westminster, SC 29693
Tel: (864) 647-9521
Fax: (864) 647-7993

WARNING

Conoflow's products are designed and manufactured using materials and workmanship required to meet all applicable standards. The use of these products should be confined to services specified and/or recommended in the Conoflow catalogs, instructions, or by Conoflow application engineers.

To avoid personal injury or equipment damage resulting from misuse or misapplication of a product, it is necessary to select the proper materials of construction and pressure-temperature ratings which are consistent with performance requirements.

INSTRUCTION AND MAINTENANCE MANUAL **FR95 PRESSURE REGULATOR**

CAUTION: These instructions should be read carefully prior to installation, use or maintenance.

GENERAL PRODUCT OVERVIEW

Conoflow's FR95 Series Airpak®, Filter-Regulator is used to provide clean, accurate air to instruments, valves, positioners, transducers and other pneumatic control devices. This unit's design provides high flow capability, durable materials of construction and bubble tight shut-off.

The FR95 Regulator has a maximum supply pressure capability of 250 PSIG (1724 kPa) with control output settings of 0-25, 0-35, 0-60 and 0-125 PSIG (0-172, 0-241, 0-414 and 0-862 kPa). This light-weight unit boasts a high flow delivery rate and excellent droop characteristic.

This regulator is offered with ¼" NPT inlet and outlet ports, two outlet gauge ports, all aluminum construction and has a black anodized exterior for superior corrosion resistance. A handwheel or wrench knob adjustments are standard.

CAUTION: Maximum Supply Pressure is 250 PSIG (1724 kPa)

WARNING: This product is not recommended for use with flammable liquids or gasses.

MATERIALS OF CONSTRUCTION

Nozzle Assembly: Brass with Buna N Soft Seat
Range Spring: Zinc Plated Carbon Steel
Diaphragm Assembly: Buna N – Nylon Reinforced
Bowl: Aluminum – Black Anodized Coated
Body: Aluminum – Black Anodized Coated
Bonnet: Aluminum – Black Anodized Coated

SPECIFICATIONS

Maximum Supply Pressure: 250 psig (1724 kPa)
Outlet pressure ranges are determined by the last character in the regulator model number.

"C" 25 psig (172 kPa)

"D" 35 psig (241 kPa)

"F" 60 psig (414 kPa)

"G" 125 psig (862 kPa)

Proof Pressure: 150% of maximum operating

Burst Pressure: 400% of maximum operating

Flow Capacity: Cv = 0.5 (see flow chart)

Temperature Range: -40 °F to 165 °F
(-40 °C to 74 °C)

Leakage: < 20 sccm across valve

Supply Pressure Effect: 0.6 PSIG (4.0 kPa) for 25 PSIG (172 kPa) change in supply pressure (Evaluated @ 2.0 SCFM air flow)

Connections: ¼" NPT Inlet and Outlet Ports, two-¼" NPT Gauge Ports (90 Degrees from Outlet Port)

Weight: 1.6 lb

REGULATOR CLEANING

The FR95 pressure regulator is cleaned to ITT Conoflow specification ES8A 01 1 when option B is selected in position 5 of the model number.

INSTALLATION

CAUTION: The regulator must be installed with the draincock downward to allow accumulated fluid to drain out when the draincock is opened.

CAUTION: Moisture and particulates can be discharged at high speed when draincock is opened.

The FR95 can be line mounted or wall mounted using the optional wall-mount bracket and ¼” fasteners. The dimensions for the bracket bolt holes are shown in the drawing below.

Teflon tape is the preferred thread sealant for the 1/4” NPT connections.

WARNING: If the supply line is connected to the “OUT” port, regulator damage or unexpected flow through the regulator could occur.

Prior to applying inlet pressure, double check the connections and assure the wrench knob or hand wheel is backed out sufficiently to unload the range spring in the bonnet.

Carefully apply inlet pressure and check the supply connection for leakage. Adjust the output pressure by rotating the wrench knob or hand wheel clockwise and check the outlet connection for leakage.

WARNING: The handwheel or wrench knob can vibrate loose and fall out if the jam nut is not tightened.

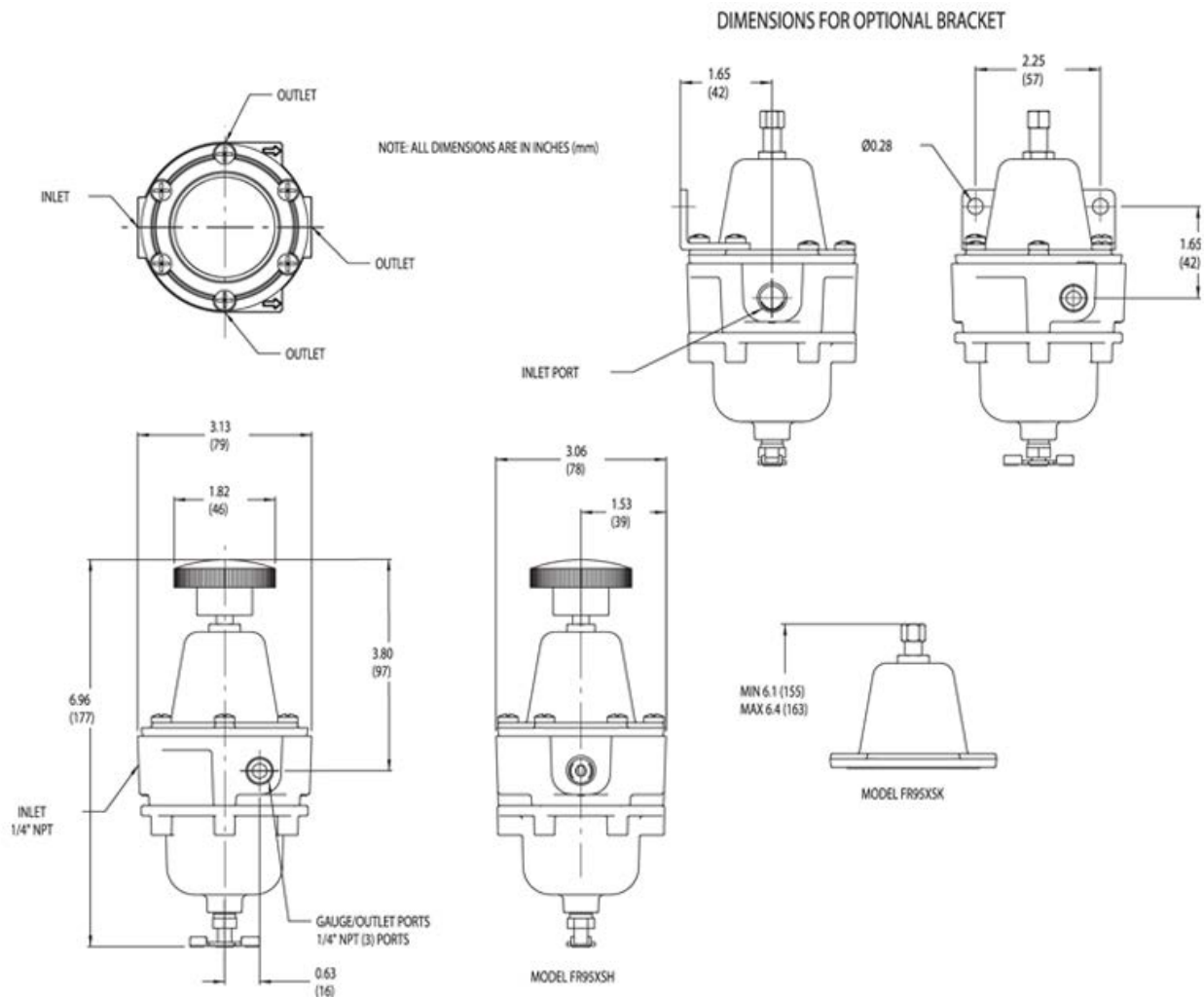

Figure 1 – Regulator dimensions with 1/4” NPT connections. Optional wall mount bracket also shown. For Certified Dimensional Drawing, Refer to A17-130

CONTROL ENGINEERING DATA

Control Engineering Data is intended to provide a single source from which one can determine, in detail, the full scope of the product line. In addition to materials of construction, diaphragm selection, filtering capabilities, it also provides all necessary data for gauge options and control output setting ranges. Control Engineering Data also provides a means of communicating, by way of an 11digit model number, a full description of the product selection.

Characters 1-4: (Filter Regulator Model No.)
FR95

Character 5: Filter Options

- A** = Cellulose (10 micron) – optional
- B** = Stainless Steel (40) micron-cleaned for oxygen service) – optional
- C** = Stainless Steel (40 micron) – optional
- X** = Polypropylene (35 micron) – standard

Characters 6: Bonnet Options

- B** = Wall Mount Bracket – optional
- S** = Plain Bonnet - standard

Character 7: Adjustment Options

- H** = Handwheel - optional
- K** = Knob (Wrench Style) – standard
- P** = Preset (Factory Output Setting CAN be field adjusted) – optional
- C** = Tamperproof (Factory Output Setting Cannot be field adjusted)- optional

NOTE: 1. Customer must specify **OUTPUT SETTING, SUPPLY PRESSURE, and FLOW.**

Characters 8: Diaphragm Selection

- E** = Buna "N" (w/Relief, No Bleed) – standard
- M** = Buna "N" (No Bleed, No Relief) - optional

Character 9: Gauge Selections

- A** = Gauge (Brass Case) - optional
- G** = Gauge (Steel Case) – optional
- S** = Gauge (Stainless Steel Case) – optional
- X** = No Gauge – standard

NOTE: Gauges supplied with brass bourdon tubes.

NOTE: Gauges are not attached to the regulators at the factory.

Character 10: Filter Bowl Option

- 1 = Standard (Bowl Size)

NOTE: Materials of construction and cleaning specifications are the user's responsibility.

Character 11: Control Ranges

- C** = 25 psig (172 kPa)
- D** = 35 psig (241 kPa)
- F** = 60 psig (414 kPa)
- G** = 125 psig (862 kPa)

OPERATION IN SERVICE

Open upstream controls to provide the regulator supply pressure. To increase the output set pressure, rotate the knob or handwheel clockwise. To decrease the output set pressure, rotate the knob or handwheel counterclockwise. For non-relieving models (option "M" in character 8 position of the CED code), rotate the knob or handwheel counterclockwise to reduce the output pressure, when the system is flowing.

When the system is being shut down, it is an established safety practice to reduce the output pressure under flow then shut off the supply pressure to the regulator. After all pressure is relieved from the system, back out the control knob until there is no spring resistance felt on the control knob. This will assure that no output pressure will be generated when the supply pressure to the regulator resumes, the next time the system is used.

NOTE: The downstream pressure will change as the flow changes. As the flow increases, the delivery pressure will decrease. See the FR95 representative flow performance graphs for this product.

NOTE: The outlet set pressure will change as the inlet pressure changes. The output set pressure will increase as the supply pressure decreases at a rate of 0.6 psi per 25 psi decrease in the inlet pressure.

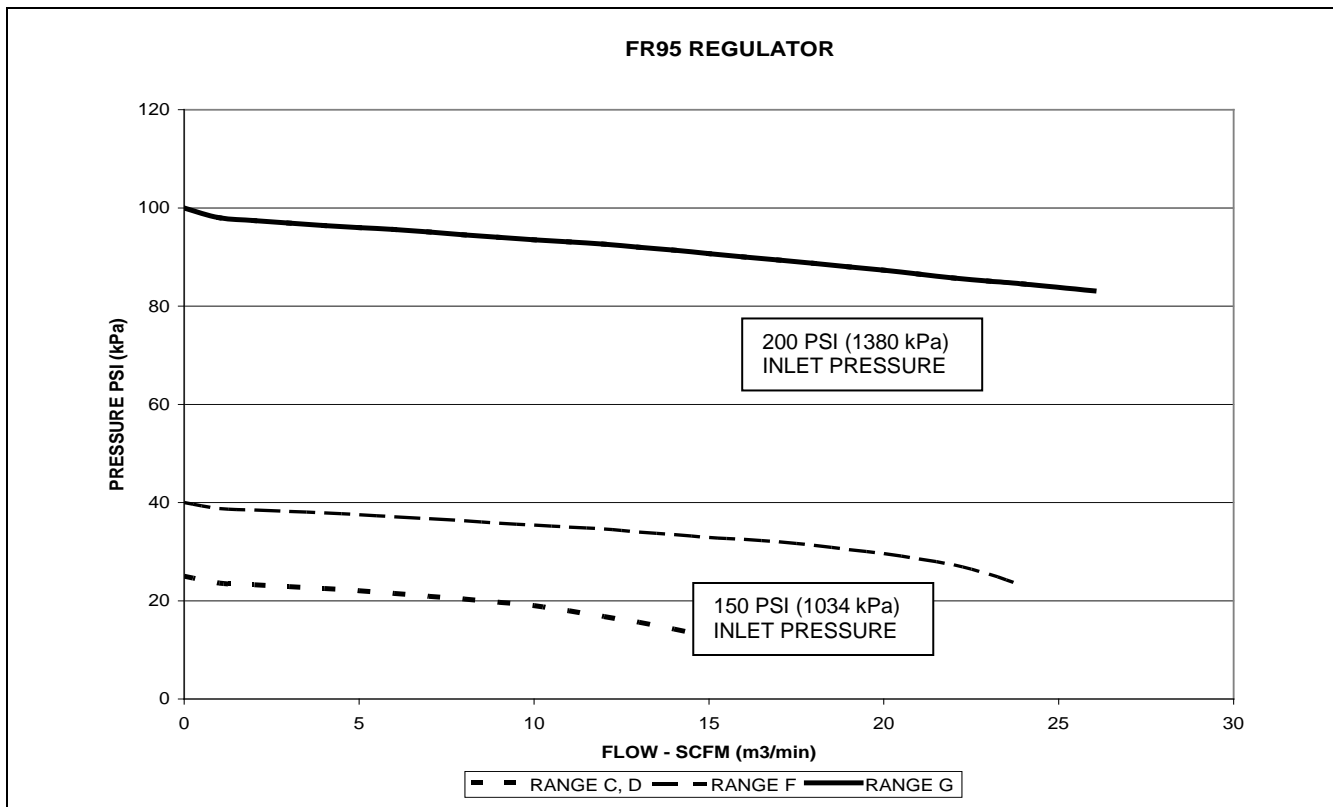

TROUBLESHOOTING GUIDE

Symptom: Outlet pressure continues to rise after flow ceases.

Potential Cause: Valve seat leakage

Repair: Disassemble and clean regulator components. Install new valve plug and filter element (if applicable). Reassemble.

Symptom: External leakage

Potential Cause: Diaphragm to body joint seal leakage.

Repair: Disassemble. Inspect regulator body where diaphragm seals. Replace diaphragm.

Potential Cause: Bowl to body joint leakage.

Repair: Disassemble. Inspect regulator body where bowl o-ring contacts. Inspect bowl where o-ring contacts. Replace o-ring.

Potential Cause: Draincock leakage.

Repair: Tighten draincock by turning handle clockwise.

Symptom: Outlet pressure cannot be adjusted to maximum control range.

Potential Causes:

1. Control knob positive stop adjustment.
2. Flow induced droop.

Repair:

1. Adjust positive stop of control knob.
2. See NOTE in above OPERATION IN SERVICE instructions and flow curves for explanation – a higher range regulator may be required.

Symptom: Noisy operation.

Potential Causes: Turbulence in adjacent piping.

Repair: Insure that there are no elbows, line tees or other turbulence creating piping directly upstream or downstream of the pressure regulator.

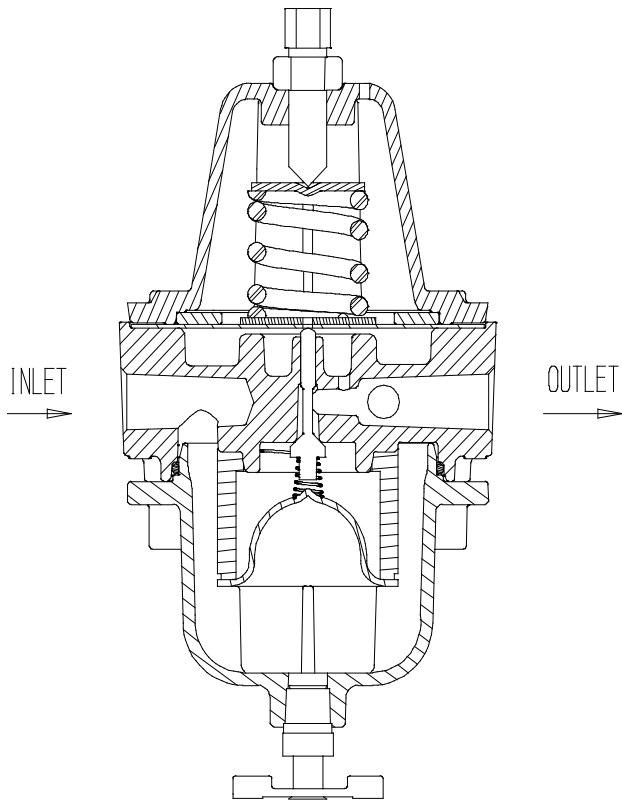

FIGURE 2 – Cross Section of FR95 Regulator

REPAIR AND MAINTENANCE

WARNING: To prevent equipment damage or injury, insure that all system pressure is relieved and the supply valve for this regulator is secured in the off position.

Cleanliness is critical to successful maintenance and repair of this product. Perform all repair work in a clean environment, with clean tools, and the correct materials and supplies.

Tools and Materials Required:

1. A vise, or other suitable fixture, to secure the regulator.
2. A Phillips screwdriver
3. Lint free swabs or wipes to clean components

DISASSEMBLY

CAUTION: The body, bonnet, and bowl are held together by 6 screws. Removal of the six screws allows these three parts, and most of the internal parts, to freely separate.

1. Secure the body of the regulator.
2. Turn control knob (1) counterclockwise until the range spring (6) is unloaded.
3. Remove the six screws (2) holding the bonnet (4) to the body (9).
4. Remove the bonnet (4).
5. Remove the spring button (5) and spring (6).
6. If present, remove the restricting plate (7).
7. Remove the diaphragm (8).
8. Remove the bowl (16) by pulling downward away from the body (9).
9. If the filter (14) remained attached to the body (9) it can be removed by gripping the filter and pulling it away

from the body. If it remained in the bowl then lift the filter out of the bowl (16).

10. To remove the plug spring (13) and plug (12), grip the plug spring and pull downward away from the body. The plug and plug spring should slide out of the body together.

ASSEMBLY

1. Replace worn or damaged components with new components.
2. Clean and inspect components for reuse. Sealing surfaces must be smooth and free of wear or scratches.
3. Replace the o-ring (11) around the bowl (16).
4. Insert the filter plate (15) into the bowl (16). Make sure it is centered.
5. Place a new filter (14) on the filter plate (15).
6. Install the valve plug (12) and plug spring (13) into the body (9) of the regulator. The tail on the plug spring should make contact with cylindrical wall around seating surface about halfway down the wall. The free end of the plug spring needs to be centered with respect to the cylindrical wall.
7. Carefully position the body (9), with plug and plug spring inside of it, over the bowl (16). Make sure that the two assemblies are centered with respect to each other and that the bolt holes line up. Carefully lower the body onto the bowl.

TEST FOR CORRECT ASSEMBLY TO THIS POINT:

While holding the body and bowl together, push down on the end of the plug stem and release. If the plug stem springs back up then the plug spring is contacting the filter plate correctly. If the plug stem does not spring back then the plug spring is not in the correct position. Back up to step 6 and reposition the plug spring.

NOTE: The body does not fit tightly against the bowl until the screws are tightened.

8. Place the diaphragm (8), with the metal plate up, on the body (9). If it is a relieving diaphragm, make sure that the end of the nozzle plug centers in the center hole in the diaphragm. Make sure the bolt holes in the diaphragm line up with the bolt holes in the body.
9. Place the restricting plate (7), used on the **F** and **G** range regulators, with the rounded edge mating against the diaphragm. Center the plate on the diaphragm.
10. Place the range spring (6) on the center of the metal plate of the diaphragm (8).
11. Place the spring button (5) on the top of the range spring (6) with the indentation pointing toward the diaphragm (8).
12. Carefully place the bonnet (4) over the range spring and onto the diaphragm (8). Make sure the restricting plate is centered with respect to the bonnet. Align the bolt holes of the bonnet with the bolt holes of the diaphragm, body, and bowl.
13. Insert the six 10-24 X 2" machine screws (2) through the bolt holes in the bonnet. Tighten the first screw until the head of the screw contacts the bonnet then tighten the opposite screw. Tighten the five remaining screws.

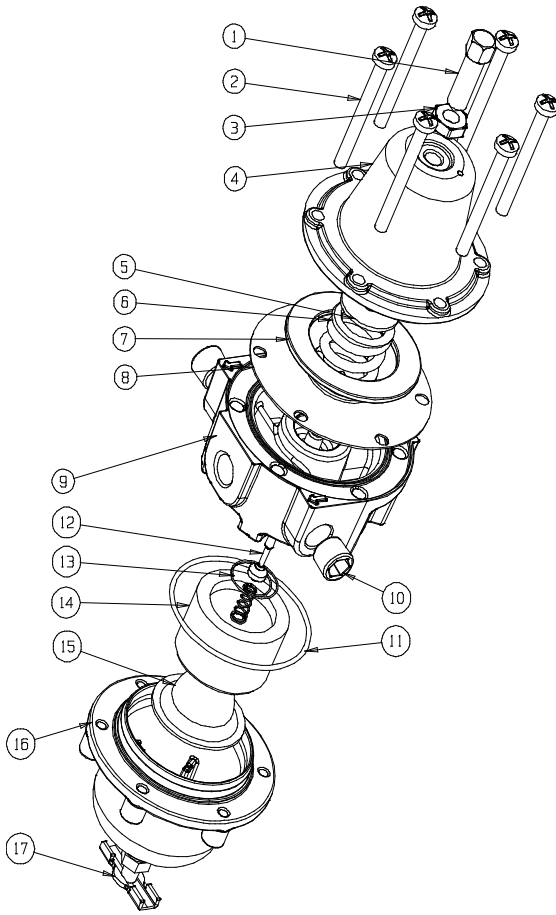

*See note 2.

Item	Description	QTY	RANGE C FR95XSKE1C	RANGE D FR95XSKE1D	RANGE F FR95XSKE1F	RANGE G FR95XSKE1G
1	Knob	1	G6017750	G6017750	G6017750	G6017750
2	Screw #10	6	G6900653	G6900653	G6900653	G6900653
3	Nut Hex Jam	1	G6900212	G6900655	G6900212	G6900212
4	Bonnet	1	G6386998	G6386998	G6386998	G6386998
5	Spring button	1	G6387037	G6387037	G6387037	G6387037
6	Spring, Range	1	G6017453	G6017453	G6017453	G6385176
7	Restricting Plt.	1			G6017487	G6017487
8*	Diaphragm	1	G6387001	G6387001	G6387001	G6387001
9	Body	1	G6386996	G6386996	G6386996	G6386996
10	Pipe Plug	2	G6900556	G6900556	G6900556	G6900556
11*	O-ring -034	1	G6077656	G6077656	G6077656	G6077656
12*	Nozzle Plug	1	G6387060	G6387060	G6387060	G6387060
13	Plug Spring	1	G6387019	G6387019	G6387019	G6387019
14*	Filter	1	G6385341	G6385341	G6385341	G6385341
15	Filter Plate	1	G6387004	G6387004	G6387004	G6387004
16	Bowl	1	G6387000	G6387000	G6387000	G6387000
17	Draincock	1	G6384623	G6384623	G6384623	G6384623

FIGURE – 3 Exploded View of the FR95

OPTIONAL ITEMS	QTY	PART NO.
18 Handwheel	1	G6017792
19 Cellulose Filter	1	G6077663
20 Stainless Steel Filter	1	G6078216
22 Bracket	1	G6387039
23 Diaphragm, no bleed no relief	1	G6387013

NOTES:

1. When ordering spare parts, specify complete Catalog No., Item No. and Part No. This will permit positive identification and rapid handling of order.
2. Spare Parts Kits
 G6387043 – Kit for regulators with relieving diaphragm. Consists of items 8, 11, 12, & 14.
 G6387044 – Kit for regulators with no bleed, no relief diaphragm. Consists of no bleed no relief diaphragm G6387013 and items 11, 12, & 14.
3. For special models (non CED codeable), consult factory for parts list.