



ITT

Engineered for life

ITT Conoflow
105 Commerce Way
Westminster, SC 29693
Tel: (864) 647-9521
Fax: (864) 647-9574

WARNING

Conoflow's products are designed and manufactured using materials and workmanship required to meet all applicable standards. The use of these products should be confined to services specified and/or recommended in the Conoflow catalogs, instructions, or by Conoflow application engineers.

To avoid personal injury or equipment damage resulting from misuse or misapplication of a product, it is necessary to select the proper materials of construction and pressure-temperature ratings which are consistent with performance requirements.

**INSTRUCTION AND MAINTENANCE MANUAL
IEEE QUALIFIED AIRPAK
MODEL GFH20XT1767C - 25 PSI (172 kPa)
GFH20XT1767F - 60 PSI (414 kPa)
GFH20XT1767G - 125 PSI (862 kPa)**

CAUTION: These instructions should be read carefully prior to installation, use or maintenance.

GENERAL PRODUCT OVERVIEW

Conoflow's Model GFH20XT1767_ Series Airpak®, Filter-Regulator has been qualified in accordance with requirements of IEEE 323-1974 and the recommended practices of IEEE 344-1975. The test program included Thermal Aging, Radiation Aging, Wear Aging, Seismic Qualification and Steam Line Break testing. For details of test conditions consult the factory.

This unit is a pressure reducing, relief type regulator and air filter combination. It is used to provide clean regulated air pressure to instruments, controls and other pneumatic devices. The Regulator has a maximum supply pressure capability of 200 PSIG (1380 kPa) with control output settings of 0-25, 0-60 and 0-125 PSIG (0-172, 0-414 and 0-862 kPa).

This regulator is offered with ¼" NPT inlet and outlet ports and two outlet gauge ports. A wrench knob adjustment is standard.

CAUTION: Maximum Supply Pressure is 200 PSIG (1380 kPa)

WARNING: This product is not recommended for use with flammable liquids or gasses.

MATERIALS OF CONSTRUCTION

Nozzle Assembly: Brass/ Stainless Steel
Range Spring: 17-7 PH Stainless Steel
Diaphragm Assembly: Brass/Viton – Nomex Reinforced
Bowl: Brass
Body: Brass
Bonnet: Brass
O-rings: Viton

SPECIFICATIONS

Maximum Supply Pressure: 200 psig (1380 kPa)
Outlet pressure ranges are determined by the last character in the regulator model number.
"C" 25 psig (172 kPa)
"F" 60 psig (414 kPa)
"G" 125 psig (862 kPa)
Flow Capacity: 16 SCFM (0.453 m3/min) (with 100 PSI (690 kPa) supply pressure)
Temperature Range: -20 °F to 150 °F (-29 °C to 66 °C)
Filter Rating: 10 micron (cellulose)
Connections: ¼" NPT Inlet and Outlet Ports, Two ¼" NPT Gauge Ports (90 Degrees from Outlet Port)
Weight: 3.12 lb (1.41 kg)

Note: IEEE Qualification validates ability to operate at higher temperatures. Temperature Range is for conformance to published specifications

GFH20-IOM 05/16

WARNING - TECHNICAL DATA SUBJECT TO EAR CONTROLS

THIS DOCUMENT CONTAINS TECHNICAL DATA WHOSE EXPORT IS RESTRICTED BY THE EXPORT ADMINISTRATION ACT OF 1979, AS AMENDED (TITLE 50, U.S.C., APP. 2401, ET SEQ.) VIOLATION OF THIS EXPORT CONTROL LAW IS SUBJECT TO SEVERE CRIMINAL PENALTIES.

STORAGE

Store per ANSI-ASME N45.2.2 Level B

INSTALLATION

CAUTION: The regulator must be installed with the draincock downward to allow accumulated fluid to drain out when the draincock is opened.

CAUTION: Moisture and particulates can be discharged at high speed when draincock is opened.

Teflon tape is the preferred thread sealant for the 1/4" NPT connections.

WARNING: If the supply line is connected to the "OUT" port, regulator damage or unexpected flow through the regulator could occur.

Prior to applying inlet pressure, double check the connections and assure the wrench knob is backed out sufficiently to unload the range spring in the bonnet.

Carefully apply inlet pressure and check the supply connection for leakage. Adjust the output pressure by rotating the wrench knob clockwise and check the outlet connection for leakage.

WARNING: The wrench knob can vibrate loose and fall out if the jam nut is not tightened.

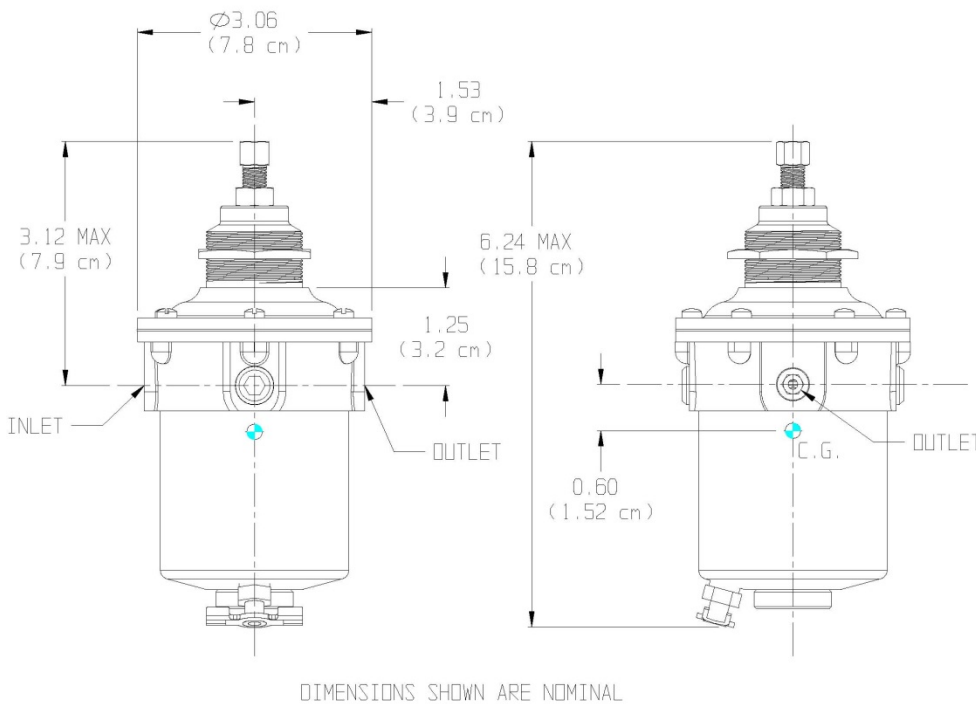

Figure 1 – Regulator dimensions with 1/4" NPT connections.
For Certified Dimensional Drawing, Refer to A17-60

OPERATION IN SERVICE

Open upstream controls to provide the regulator supply pressure. To increase the output set pressure, rotate the knob clockwise. To decrease the output set pressure, rotate the knob counterclockwise.

When the system is being shut down, it is an established safety practice to reduce the output pressure completely, then shut off the supply pressure to the regulator.

This will assure that no output pressure will be generated when the supply pressure to the regulator resumes, the next time the system is used.

NOTE: The downstream pressure will change as the flow changes. As the flow increases, the delivery pressure will decrease. See the GFH20 series representative flow performance graphs for this product.

CAUTION: The internal filter can retain moisture from wet air. If this product is used in a sufficiently cold (potentially freezing) environment, a wet filter can result in restricted or blocked flow.

NOTE: The outlet set pressure will change as the inlet pressure changes.

FLOW CHARACTERISTICS

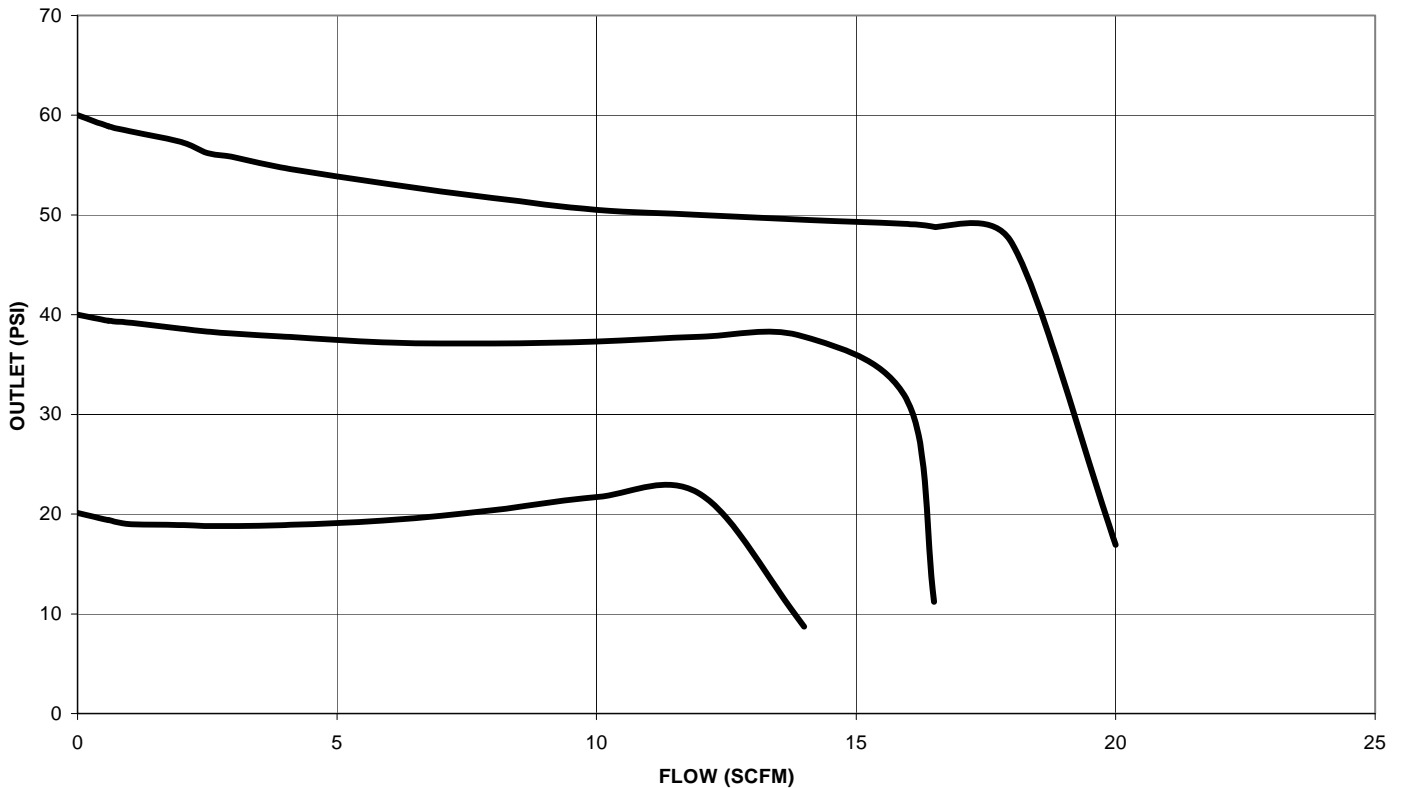

TYPICAL AIR FLOW PERFORMANCE

TROUBLESHOOTING GUIDE

Symptom: External leakage

Potential Cause: Diaphragm to body joint seal leakage.

Repair: Disassemble. Inspect regulator body where diaphragm seals. Replace diaphragm.

Potential Cause: Bowl to body joint leakage.

Repair: Disassemble. Inspect regulator body where bowl o-ring contacts. Inspect bowl where o-ring contacts. Replace o-ring.

Potential Cause: Draincock leakage.

Repair: Tighten draincock by turning handle clockwise.

Symptom: Outlet pressure cannot be adjusted to maximum control range.

Potential Causes:

1. Control knob positive stop adjustment.
2. Flow induced droop.

Repair:

1. Adjust positive stop of control knob.
2. See NOTE in above OPERATION IN SERVICE instructions and flow curves for explanation – a higher range regulator may be required.

Symptom: Noisy operation.

Potential Causes: Turbulence in adjacent piping.

Repair: Insure that there are no elbows, line tees or other turbulence creating piping directly upstream or downstream of the pressure regulator.

Symptom: Excessive air consumption.

Potential Cause: Wear to diaphragm assembly.

Repair: Replace diaphragm assembly.

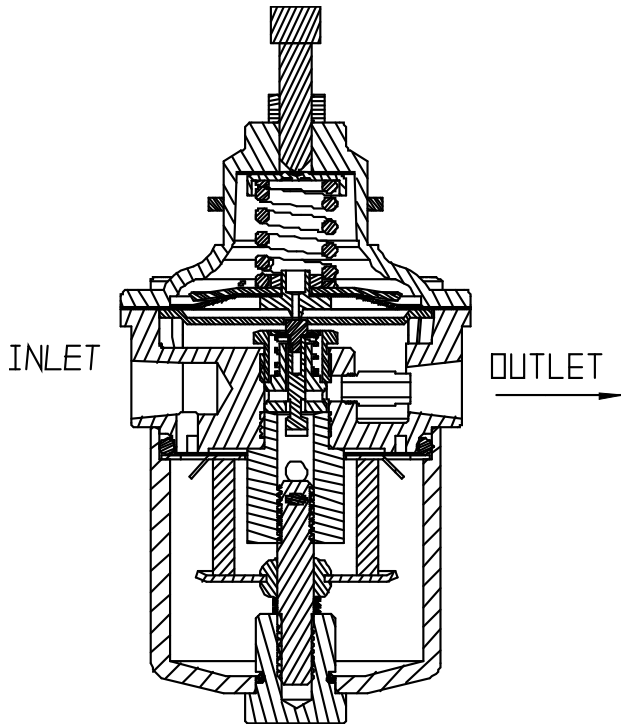

FIGURE 2 – Cross Section of GFH20 Regulator

REPAIR AND MAINTENANCE

WARNING: To prevent equipment damage or injury, insure that all system pressure is relieved and the supply valve for this regulator is secured in the off position.

Cleanliness is critical to successful maintenance and repair of this product. Perform all repair work in a clean environment, with clean tools, and the correct materials and supplies.

Tools and Materials Required:

1. A vise, or other suitable fixture, to secure the regulator.
2. A Phillips torque screwdriver
3. A torque wrench with a 5/8" socket
4. Lint free swabs or wipes to clean components

DISASSEMBLY

1. Secure the body of the regulator.
2. Turn control knob (1) counterclockwise until the range spring (7) is unloaded.
3. Remove the six screws (4) holding the bonnet (5) to the body (12).
4. Remove the bonnet (5).
5. Remove the spring button (6) and spring (7).
6. If present, remove the restricting plate (8).
7. Remove the diaphragm SA (9).
8. Remove the baffle plate (10).
9. Loosen the nozzle retaining nut and remove the nozzle (11).
10. Remove the dripwell (22) by unscrewing the cap nut (24) and pulling downward away from the body (12).
11. To remove the filter remove the filter spring (21) and the filter plate (19) with attached grommet (20).
12. To remove the bowl o-ring remove the retaining plate (16).
13. Remove the cap nut o-ring (23) from the groove in the cap nut (24)

ASSEMBLY

1. Replace worn or damaged components with new components.
2. Clean and inspect components for reuse. Sealing surfaces must be smooth and free of wear or scratches.
3. Replace the o-ring (23) around the cap nut (24).
4. Place the bowl o-ring (15) on the o-ring groove of the body (12).
5. Insert the retaining plate (16) into the body (12). Place the filter (18), filter plate (19) with attached grommet (20) and filter spring (21) onto the post sub-assembly (17).
6. Slide the bowl (22) onto the body until it is firmly seated against the bottom of the body (12).
7. Slide the o-ring (23) onto the cap nut groove and screw into the bottom of the bowl (22) until it is finger tight. Insure that the bowl is seated against the bottom of the body.
8. Install the nozzle SA (11) into the body and torque the nozzle retaining nut to 100 in. lbs.
9. Ensure that the baffle plate (10) is installed in the groove in the body (12) before installing the diaphragm SA (9). Install restricting plate (8) if present.
10. Place spring (7) and spring plate (6) on to diaphragm.
11. Place bonnet (5) onto body lining up holes in body and diaphragm SA
12. Install the 6 bonnet screws (4) and torque in a star pattern to 32 inch pounds.

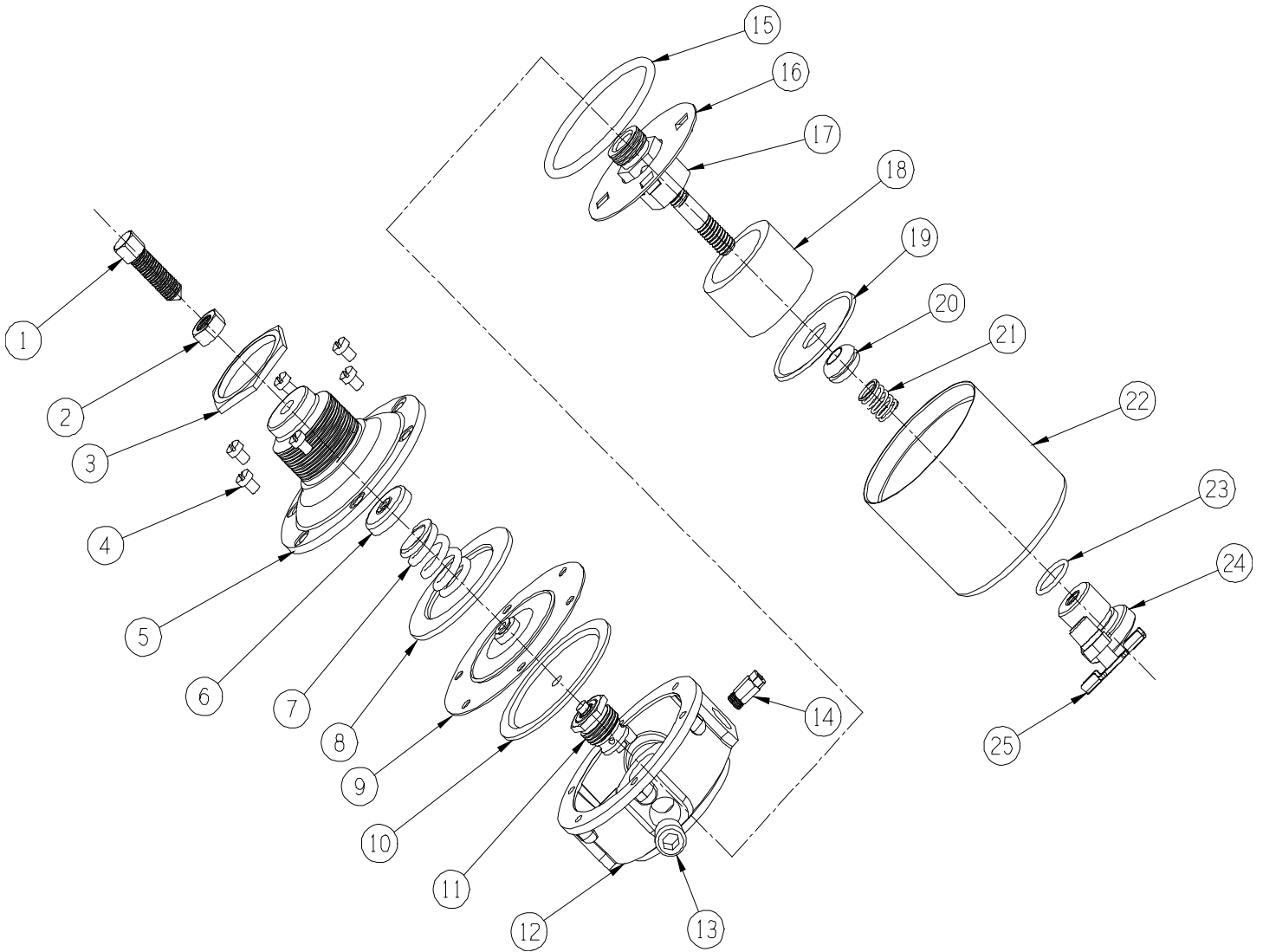

FIGURE – 3 Exploded View of the GFH20 Airpak

ITEM NO.	QUANTITY	DESCRIPTION / MATERIAL	PART NO.
1	1	Adjusting Knob / SZP	G6017750
2	1	Hex Jam Nut / 18-8 SS	G6900211
3	1	Panel Lock nut / SZP	G6017628
4	6	Bonnet Screws / 18-8 SS	G6900046
5	1	Bonnet / Brass	G6017412
6	1	Spring Plate / SZP	G6018857
7	1	Range Spring 0-25 PSI	G6019997
7	1	Range Spring 0-60 & 0-125 PSI	G6386405
8	1	Restricting Plate (0-125 PSI Only) / SZP	G6017487
9 (2)	1	Diaphragm SA 0-25 & 0-60 PSI / Brass/Viton	G6374051
9 (2)	1	Diaphragm SA 0-125 PSI / Brass/Viton	G6377832
10	1	Baffle Plate / Brass	G6374085
11 (2)	1	Nozzle SA - Brass / Stainless	G6347843
12	1	Body / Brass	G6374036
13	2	¼ NPT Pipe Plug / 18-8 SS	G6900529
14	1	Aspirator Nozzle / Brass	G6017982
15 (2)	1	Bowl O-Ring / Viton	G6374077
16	1	Retaining Plate / Brass	G6357537
17	1	Post SA / Brass / 416 SS	G6374044
18 (2)	1	Filter / Cellulose	G6077663
19	1	Filter Plate / Brass	G6017263
20	1	Grommet / Neoprene	G6077283
21 (2)	1	Filter Spring / Stainless	G6017289
22	1	Dripwell (Bowl) / Brass	G6386857
23 (2)	1	O-Ring / Viton	G6374069
24	1	Cap Nut / Brass	G6357545
25	1	Draincock / Brass	G6386542
26	1	Nameplate (not shown)	G6385604

NOTES:

1. When ordering spare parts, specify complete Catalog No., Item No. and Part No. This will permit positive identification and rapid handling of order. Spare parts are commercial grade only.