

GH20VT SERIES (Brass)

Conoflow's Vacuum Regulators are designed to accurately regulate the sub-atmospheric pressure of a vessel being evacuated. These units are especially suited for laboratory work and test stands for simulation of high altitude conditions.

PRINCIPLES OF OPERATION

These units are used to provide a regulated vacuum. Turning the handwheel changes the force exerted by the range spring on the diaphragm assembly. Additional forces are exerted on the diaphragm assembly at atmospheric pressure underneath the top diaphragm and the regulated vacuum above it. Equilibrium is reached when all three of these forces are in balance. The forces from the lower diaphragm are negligible due to its reduced effective area. If the regulated vacuum drops below the set point, there is a net downward force on the diaphragm assembly which causes the nozzle to open. This allows the vacuum pump to increase the vacuum in the control chamber and in the regulator bonnet. As the vacuum increases, the upward force on the diaphragm assembly increases. This causes the diaphragm assembly to move upward allowing the nozzle to close. In equilibrium, the nozzle assumes a position to provide the required flow while maintaining the vacuum at the set point. If the regulated vacuum rises above the set point, the resulting upward force on the diaphragm assembly causes the diaphragm seat to lift off of the plug. This allows air at atmospheric pressure to enter the lower diaphragm decreasing the vacuum until the set point is reached. to provide the required flow while maintaining the vacuum at the set point. If the regulated vacuum rises above the set point, the resulting upward force on the diaphragm assembly causes the diaphragm seat to lift off of the plug. This allows air at atmospheric pressure to enter the lower diaphragm decreasing the vacuum until the set point is reached.

Standard Specifications

Connections:

1/4" NPT w / 1/8" NPT Vacuum Sensing Port

Regulated Vacuum:

0-15" and 30" Hg (38.1 and 76.2 cm Hg)

Flow Capacity (Max.):

1.5 SCFM (0.04 m3/min)

Sensitivity:

0.2" H₂O (0.51 cm)

Ambient Temperature Range:

-20°F to +150°F (-29°C to +66°C) (w/Buna "N" diaphragm)

Approximate Shipping Weight:

2.75 lbs. (1.39 Kg)

Materials of Construction

Body:

Brass

Bonnet:

Brass

Diaphragm Assembly:

Buna "N"

Nozzle Assembly:

Brass Body / Stainless Steel Plug

Range Spring:

Steel Plated

Dimensional Drawing A17-5 is available upon request.



GH20VT SERIES (Brass)

PRODUCT CONFIGURATION CODING

Product configuration coding is intended to provide a single source from which one can determine, in detail, the full scope of the product line. In addition to materials of construction, diaphragm selection and filtering capabilities, it also provides all necessary data, regarding adjustment options and range selections. Control Engineering Data also provides a means of communicating, by way of a code number, which is fully descriptive of the product selection.

NOTE: 1. Catalog numbers as received must contain twelve (12) characters.

Ordering Sequence — Select desired option for each category

TEXT POSITION 1 through 4	OPTION CODE GH20	DEFINITION OF CHARACTER Regulator - Vacuum
5	V	OPERATIONAL FEATURES Vacuum Service
6	F S T	BONNET OPTIONS Tapped Bonnet for Flush Back Panel Mounting Plain Bonnet Threaded Bonnet - (Standard)
7	H K	ADJUSTMENT SELECTIONS Handwheel (Standard) Knob (Wrench Style)
8	D E G H J L	DIAPHRAGM SELECTIONS Neoprene (w/Relief, No Bleed) Buna "N" (w/Relief, No Bleed) Silicone on Glass (w/Relief, No Bleed) Teflon (Sandwich Type - w/Relief, No Bleed) Viton on Nomex (w/Relief, No Bleed) Nordel on Nomex (EPDM) (w/Relief, No Bleed)
9	X	SEAT SELECTIONS (Standard) - Metal to Metal Seat
10	X	MATERIAL OPTIONS (Standard) - Brass
11	X A	CLEANING OPTIONS (Standard) (Cleaned for Oxygen Service)
12	N P	RANGE SELECTIONS 0-15" Hg (0-5 PSI) 0-30" Hg (0-15 PSI)

GH20VT SERIES (Brass)

Dimension Specifications

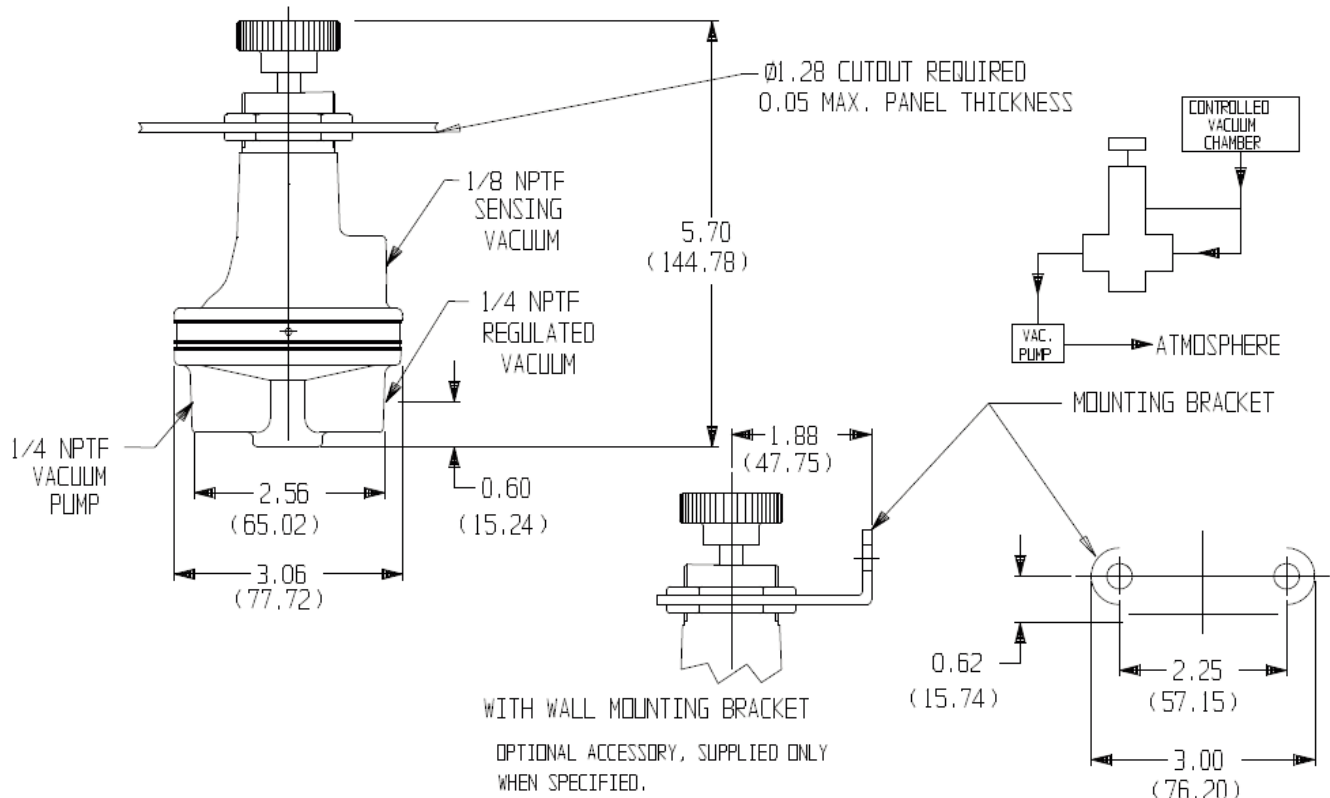

Example

