

GH10 SERIES (303 Stainless Steel Internals)

Conoflow's GH10 Manual Loading Regulators are precision units designed for use in laboratory environments, remote loading of pneumatic devices, speed changers and other general purpose applications.

PRINCIPLES OF OPERATION

Turning the handwheel changes the force exerted by the range spring on the diaphragm assembly. In equilibrium, the force exerted by the range spring is balanced by the force from the output pressure acting underneath the diaphragm assembly. An unbalance between the output pressure and the range spring force causes a corresponding reaction in the diaphragm and nozzle assemblies. If the output pressure rises above the set pressure, the diaphragm seat is lifted from the plug, venting the excess pressure to atmosphere until equilibrium is reached. If the output pressure drops below the set pressure, the unbalanced force from the range spring acts through the diaphragm assembly unseating the nozzle plug. This allows supply pressure to flow through the nozzle to the downstream port increasing the output pressure. The output pressure increases until it balances the force on the diaphragm assembly by the range spring. The constant bleed feature is used in applications where the flow demand is low. The constant bleed keeps the diaphragm in a dynamic state by preventing the nozzle from closing completely. This increases both the sensitivity and the stability of the regulator. A no bleed/no relief diaphragm assembly are used to prevent the process medium from exhausting to atmosphere. This option is typically used with liquids and toxic gases. The principle of operation is the same as above except that excess output pressure is not vented to atmosphere. Instead, as the diaphragm seat lifts off of the plug and the nozzle closes, the excess pressure is relieved downstream.

Standard Specifications

Maximum Supply Pressure:

300 PSI (2068 kPa)

Regulated Output Pressure Ranges:

0-3, 5, 15, 25, 35, 50 and 125 PSI (0-21, 35, 103, 172, 241, 345, and 862 kPa)

Connections:

1/4" NPT (No Gauge Ports)

Sensitivity:

0.20" (0.51 cm) H₂O (w/relief and bleed)

Supply Pressure Effect:

0.1 PSI for 25 PSI (0.69 kPa for 172 kPa) change in supply pressure

Ambient Temperature Range:

-20°F to +150°F (-29°C to +66°C) (w/Buna "N" diaphragm)

Approximate Shipping Weight:

2.00 lbs. (0.91 Kg)

Materials of Construction

Body:

316 Stainless Steel

Bonnet:

316 Stainless Steel

Diaphragm Assembly:

Teflon/Buna "N"/Teflon

Nozzle Assembly:

302/303 Stainless Steel

Range Spring:

316 Stainless Steel

Dimensional Drawing A17-2 is available upon request.



GH10 SERIES (303 Stainless Steel Internals)

PRODUCT CONFIGURATION CODING

Product configuration coding is intended to provide a single source from which one can determine, in detail, the full scope of the product line. In addition to materials of construction, diaphragm selection and filtering capabilities, it also provides all necessary data, regarding adjustment options and range selections. Control Engineering Data also provides a means of communicating, by way of a code number, which is fully descriptive of the product selection.

NOTE: 1. Catalog numbers as received must contain twelve (12) characters.

Ordering Sequence — Select desired option for each category

TEXT POSITION 1 through 4	OPTION CODE GH10	DEFINITION OF CHARACTER
		Manual Loading Regulator
5	X	OPERATIONAL FEATURES (Standard)
6	F S T	BONNET OPTIONS Tapped Bonnet for Flush Back Panel Mounting NOTE: This option is standard on the GH10XF. Plain Bonnet Threaded Bonnet w/ 1/8" NPT Tapped Vent (Standard)
7	B H K	ADJUSTMENT SELECTIONS Long Handwheel w/Full Hex Nut Handwheel (Standard) Knob (Wrench Style)
	NOTE:	Optional Factory Pre-Set output setting CAN be field adjusted and Tamperproof Factory output setting CANNOT be field adjusted) are available as specials (Please consult factory for details).
8	A B C D E F G H J L M N P R	DIAPHRAGM SELECTIONS Teflon (Rubber Backed) Corrosive Service On Process Side (No Bleed, No Relief) Silicone on Glass (No Bleed, No Relief) Buna "N" (w/Relief and Bleed) (See Note 1) Neoprene (w/Relief, No Bleed) Buna "N" (w/Relief, No Bleed) Viton on Nomex (No Bleed, No Relief) Silicone on Glass (w/Relief, No Bleed) Teflon (Sandwich Type - w/Relief, No Bleed) Viton on Nomex (w/Relief, No Bleed) Nordel on Nomex (EPDM) (w/Relief, No Bleed) Buna "N" (No Bleed, No Relief) Nordel on Nomex (EPDM) (No Bleed, No Relief) Neoprene (No Bleed, No Relief) Teflon (Sandwich Type - w/Relief and Bleed) (See Note 1)
	NOTE:	1. This option cannot be supplied in 316 Stainless Steel construction.
9	A B C X	SEAT SELECTIONS Buna "N" Neoprene Viton Metal to Metal (Standard)
10	K	MATERIAL OPTIONS Stainless Steel Construction (302 / 303 Stainless Steel Internals)
11	A X	CLEANING OPTIONS Cleaned for Oxygen Service (Standard)
12	L A B C D E F G	RANGE SELECTIONS 0-3 PSI (0-21 kPa) 0-5 PSI (0-35 kPa) 0-15 PSI (0-103 kPa) 0-25 PSI (0-172 kPa) 0-35 PSI (0-241 kPa) 0-50 PSI (0-345 kPa) 0-60 PSI (0-414 kPa) 0-125 PSI (0-862 kPa)

GH10 SERIES (303 Stainless Steel Internals)

Dimension Specifications

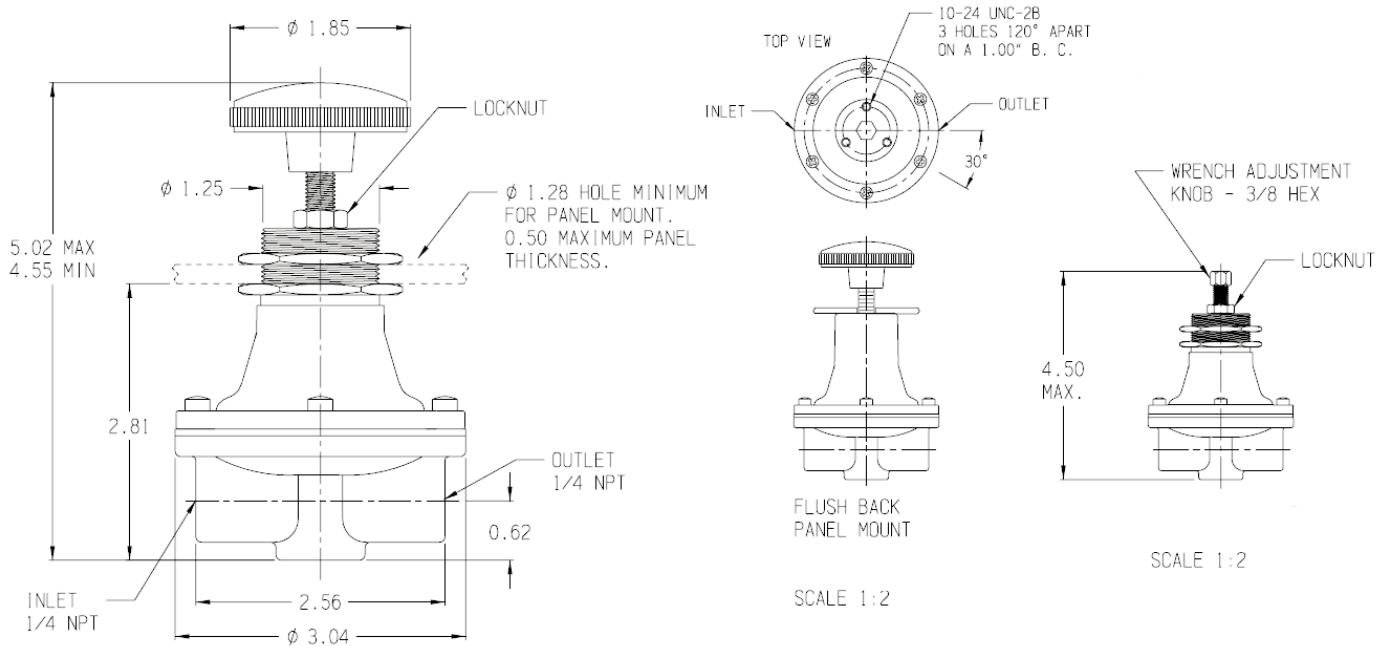

Example

