

GH20 SERIES (303 Stainless Steel Internals)

Conoflow's Service (GH20 Series) Regulators are rugged units with flow capacities and performance characteristics which allow the units to operate in both instrument and industrial applications. Buna "N" diaphragms are standard in the aluminum units.

PRINCIPLES OF OPERATION

Turning the wrench style knob changes the force exerted by the range spring on the diaphragm assembly. In equilibrium, the force exerted by the range spring is balanced by the force from the output pressure acting underneath the diaphragm assembly. An unbalance between the output pressure and the range spring force causes a corresponding reaction in the diaphragm and nozzle assemblies. If the output pressure rises above the set pressure, the diaphragm seat is lifted from the plug, venting the excess pressure to atmosphere until equilibrium is reached. If the output pressure drops below the set pressure, the unbalanced force from the range spring acts through the diaphragm assembly unseating the nozzle plug. This allows supply pressure to flow through the nozzle to the downstream port increasing the output pressure. The output pressure increases until it balances the force on the diaphragm assembly by the range spring. At equilibrium, the plug assumes a position which supplies the required flow while maintaining the output pressure at the set pressure.

Standard Specifications

Maximum Supply Pressure:

300 PSI (1379 kPa)

Regulated Output Pressure Ranges:

0-25, 60 and 125 PSI (0-172, 414, and 862 kPa)

Connections:

1/4" NPT (No Gauge Ports)

Sensitivity:

0.05" PSI (0.345 kPa)

Supply Pressure Effect:

0.12 PSI (0.827 kPa) for 25 PSI (172 kPa) change in supply pressure

Ambient Temperature Range:

-20°F to +150°F (-29°C to +66°C) (w/Buna "N" diaphragm)

Approximate Shipping Weight:

1.75 lbs. (0.79 Kg)

Materials of Construction

Body:

316 Stainless Steel

Bonnet:

316 Stainless Steel

Diaphragm Assembly:

Teflon / Buna "N"

Nozzle Assembly:

302 / 302 Stainless Steel

Range Spring:

316 Stainless Steel



GH20 SERIES (303 Stainless Steel Internals)

PRODUCT CONFIGURATION CODING

Product configuration coding is intended to provide a single source from which one can determine, in detail, the full scope of the product line. In addition to materials of construction, diaphragm selection and filtering capabilities, it also provides all necessary data, regarding adjustment options and range selections. Control Engineering Data also provides a means of communicating, by way of a code number, which is fully descriptive of the product selection.

NOTE: 1. Catalog numbers as received must contain twelve (12) characters.

Ordering Sequence — Select desired option for each category

TEXT POSITION 1 through 4	OPTION CODE GH20	DEFINITION OF CHARACTER Service Regulator
5	X	OPERATIONAL FEATURES (Standard)
6	F S T NOTE:	BONNET OPTIONS Tapped Bonnet for Flush Back Panel Mounting (3 hole - GH20) Plain Bonnet Threaded Bonnet - w / 1/8" NPT Tapped Vent - (Standard) For list price adder, refer to price list.
7	H K NOTE:	ADJUSTMENT SELECTIONS Handwheel (Optional) Knob (Wrench Style) - (Standard) GH20 Optional Factory Pre-Set output setting CAN be field adjusted and Tamperproof Factory output setting CANNOT be field adjusted) are available as specials (Please consult factory for details).
8	A B D E F G H J K L M N P R	DIAPHRAGM SELECTIONS Teflon (Rubber Backed) Corrosive Service On Process Side (No Bleed, No Relief) Silicone on Glass (No Bleed, No Relief) Neoprene (w/Relief, No Bleed) Buna "N" (w/Relief, No Bleed) Viton on Nomex (No Bleed, No Relief) Silicone on Glass (w/Relief, No Bleed) Teflon (Sandwich Type - No Bleed, w/Relief) Viton on Nomex (w/Relief, No Bleed) Teflon (Sandwich Type - No Bleed, No Relief) Nordel on Nomex (EPDM) (w/Relief, No Bleed) Buna "N" (No Bleed, No Relief) Nordel on Nomex (EPDM) (No Bleed, No Relief) Neoprene (No Bleed, No Relief) Teflon (Sandwich Type - w/Relief and Bleed)
9	X	SEAT SELECTIONS Metal to Metal (Standard)
10	K	MATERIAL OPTIONS 316 Body / 316 Bonnet / 302-303 Internals (Standard)
11	A X	CLEANING OPTIONS Cleaned for Oxygen Service (Standard) - Unless option code is specified
12	C F G	RANGE SELECTIONS 0-25 PSI (0-172 kPa) 0-60 PSI (0-414 kPa) 0-125 PSI (0-862 kPa)

GH20 SERIES (303 Stainless Steel Internals)

Dimension Specifications

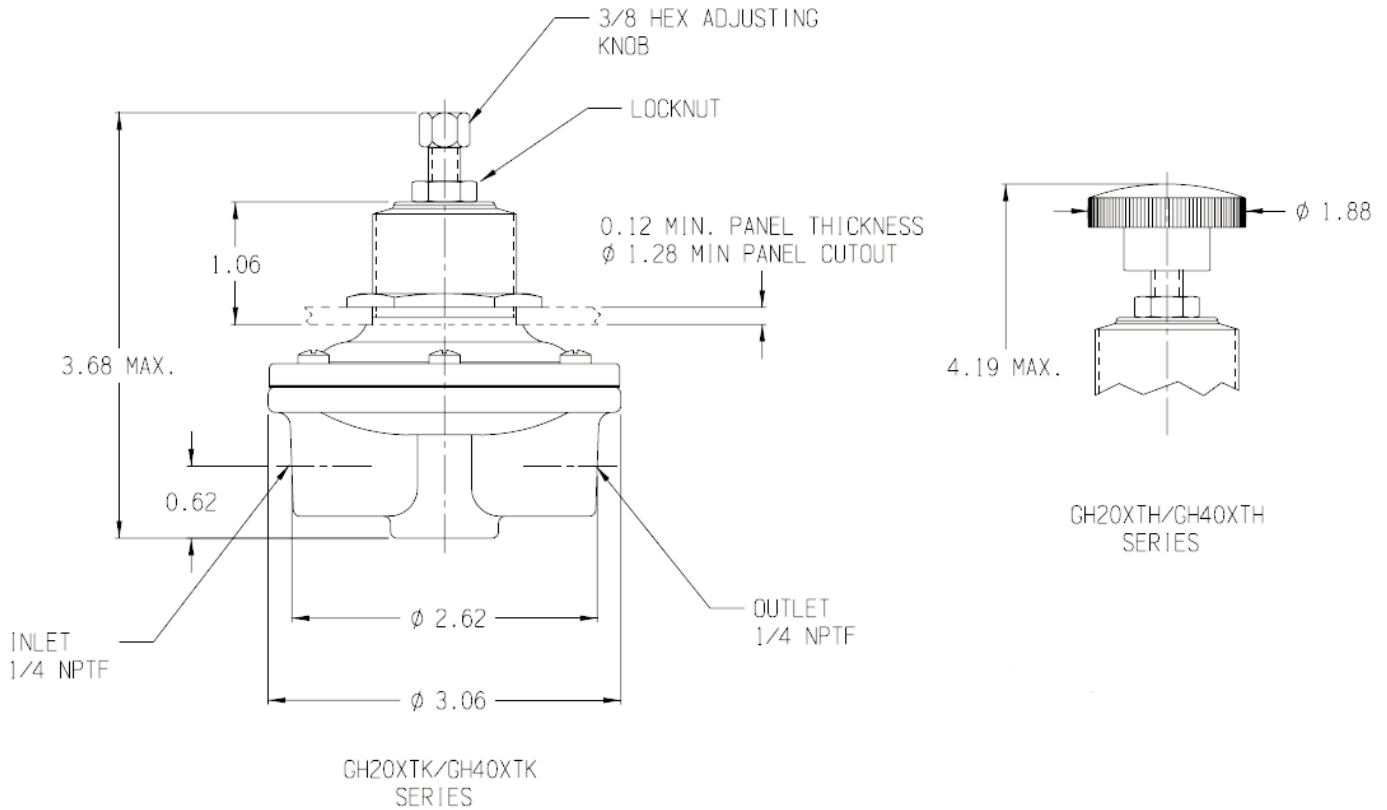

Example

