

Plasma Cutting System

GH10 Series Manual Loading Regulator

Over twenty years ago the Plasma Cutting Industry started to mechanize plasma cutting technology. Initially, companies recognized that equipment manufacturers were not adequately addressing the critical process parameter of "arc voltage" (torch height). Torch height control systems have been developed for precise control, they not only set and maintain critical arc voltage parameters but also provide additional features that significantly improve efficiency and productivity.

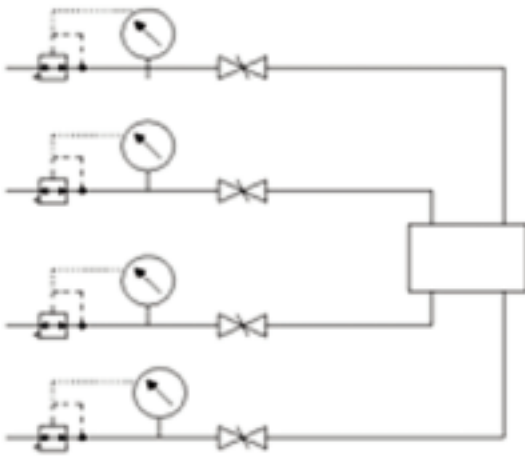

The four GH10 Series Manual Loading Regulators required for this application each have a modified mounting bracket that adapts to a small servo motor. The motors receive a 4-20 mA DC signal from four corresponding pressure transducers. The regulators control the pressure of the four types of gases to the cutting nozzle. A pre-flow gas which is an arc starting gas, a plasma gas which is a cutting gas, a shielding gas which surrounds the arc and a post flow gas.

The plasma cutting machines are used to cut sheet plate into various precise forms. The thickness of the plate varies from 0.25" up to 2". The plate is positioned on a cutting table and the pressurized nozzle via the various gas mixtures creates a high temperature cutting arc, which cleanly cuts a predetermined shape or form.

