



ITT

Engineered for life

Conoflow
5154 Hwy. 78
P.O. Box 768
St. George, SC 29477
Tel: (843) 563-9281
Fax: (843) 563-2131

WARNING

Conoflow's products are designed and manufactured using materials and workmanship required to meet all applicable standards. The use of these products should be confined to services specified and/or recommended in the Conoflow catalogs, instructions, or by Conoflow application engineers.

To avoid personal injury or equipment damage resulting from misuse or misapplication of a product, it is necessary to select the proper materials of construction and pressure-temperature ratings which are consistent with performance requirements.

INSTRUCTION AND MAINTENANCE MANUAL HP635 HIGH PURITY PRESSURE REGULATOR

CAUTION: These instructions should be read carefully prior to installation, use or maintenance.

GENERAL PRODUCT OVERVIEW

The HP635 high purity pressure regulator is a handwheel adjustable, spring loaded pressure reducing regulator. This diaphragm sensed HIGH PURITY regulator is designed to provide significant flow and accurate pressure regulation of purge gas as well as some hazardous gasses.

This regulator uses a large main valve, providing a flow capacity of Cv= 1.8 at the valve. The actual flow through this product is dependant on connection selection and operating conditions (see catalog flow graphs).

MATERIALS OF CONSTRUCTION

The HP635 pressure regulator will operate with any inert purge gas. This regulator is available with corrosion resistant materials of construction which permit use with some corrosive or other hazardous gasses.

Body	Brass or type 316 Stainless Steel
Bonnet	Nickel plated Brass
Diaphragm	Type 316L Stainless Steel
Valve Seat	PCTFE (Kel-F)
Valve Trim	Type 316 Stainless Steel
Filter Screen *	Type 316 Stainless Steel

* Filter Screen is used in 1/2" NPT ported body only

REGULATOR CLEANING

The HP635 pressure regulator is cleaned to ITT Conoflow specification ES8A 01 294.

OXYGEN SERVICE

Specification of materials in regulators used for oxygen service is the USER'S RESPONSIBILITY. Cleaning for

oxygen service, per ITT Conoflow specification ES8A 01 297 is available at no additional cost.

CAUTION: Maximum Inlet Pressure is 500 PSIG (3.45 MPa)

SPECIFICATIONS

Maximum Supply Pressure: 500 psig (3.45 MPa)

Outlet Pressure Ranges:

Outlet pressure ranges are determined by the last character in the regulator model number.

"A"	25 psig (0.17 MPa)
"B"	50 psig (0.34 MPa)
"C"	100 psig (0.69 MPa)
"D"	150 psig (1.04 MPa)
"L"	200 psig (1.38 MPa)

Proof Pressure: 150% of maximum operating
Burst Pressure: 400% of maximum operating

Flow Capacity: Cv = 1.8 at valve (see flow charts)

Temperature Range: -40 °F to 165 °F
(-40 °C to 74 °C)

Leakage: 2 x 10⁻⁸ atm cc/sec Helium
(Inboard and across valve)

Supply Pressure Effect: 6.5 psi increase per 100 psi decrease in inlet pressure.

Maximum Operating Torque: 25 in-lb

Regulator Connections: 1/2" Tube Stubs or 1/2" NPT

Weight: 5 lb

The inlet port is labeled "IN" (stamped adjacent to the port on the side of the regulator body), while the outlet port is labeled "OUT" (stamped adjacent to the port on the side of the regulator body).

INSTALLATION

The HP635 can be line mounted in any position, or mounted in a panel with the optional panel mounting nuts. Teflon tape is the preferred thread sealant when the regulator is installed (1/2" NPT option)

CAUTION: If the supply line is connected to the "OUT" port, regulator damage or unexpected flow through the regulator could occur.

CAUTION: When using this regulator with hazardous gasses, assure there is sufficient ventilation in the unlikely event of diaphragm failure.

Prior to applying inlet pressure, double check the connections and assure the control knob is backed out sufficiently to unload the range spring in the bonnet.

Carefully apply inlet pressure and check the supply connection for leakage. Adjust the output pressure by rotating the control knob clockwise and check the outlet connection for leakage.

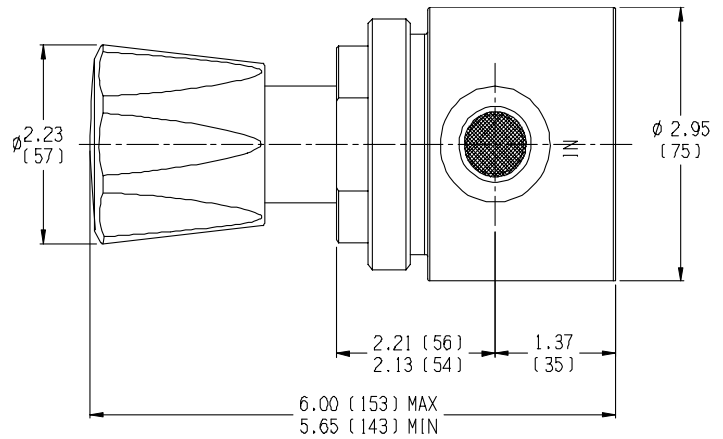

Figure 3 – Regulator dimensions with 1/2" NPT ports.

PANEL MOUNT DIMENSION DATA

Hole Cutout: \varnothing 1.32 (33)

Max Panel Thickness:

0.50 (12.7) Thick (1 Locknut)

0.25 (6.4) Thick (2 Locknut)

Locknuts are 0.12 (3.2) Thick.

INSTALLATION GEOMETRY DATA

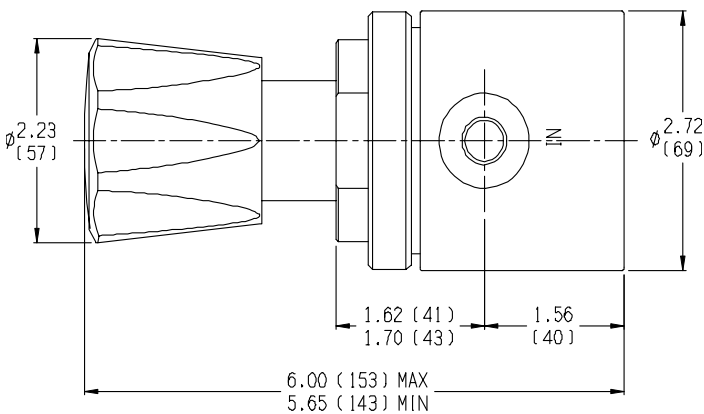

Figure 1 – Regulator dimensions with 1/2" tube stubs.

CONTROL KNOB POSITIVE STOP FEATURE

The HP635 regulator is equipped with a positive stop hand knob. This feature lets the installer adjust or pre set the maximum output pressure of the regulator.

To use this feature adjust the regulator to the desired maximum output pressure, remove the knob hole plug by prying it out with a small screwdriver, loosen the jam nut while preventing knob rotation, screw the knob down the adjustment screw until it contacts the top of the bonnet (or the control panel, if installed in a panel), back the knob out 1/8 turn, tighten the jam nut (at least 70 in-lb) and replace the hole cover on the knob.

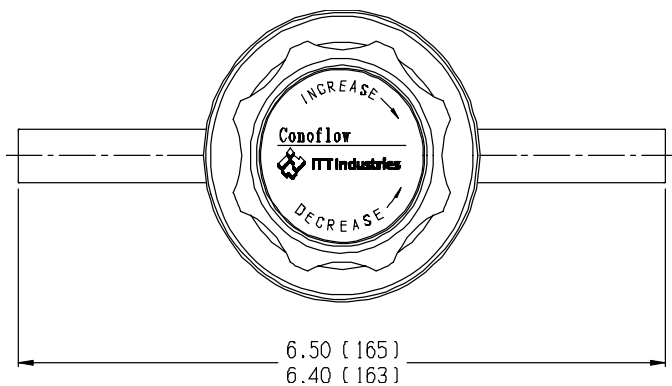

Figure 2 – Regulator tube stub dimensions.

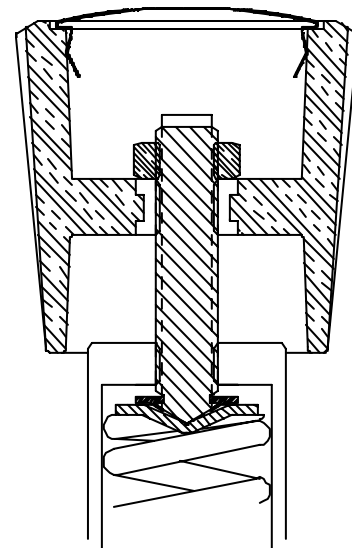

Figure 4 – Cross Section of Control Knob

WARNING: When adjusting the control knob positive stop, verify that the output pressure does not exceed the maximum control range of the regulator.

NOTE: The outlet set pressure will change as the inlet pressure changes. The output set pressure will increase as the supply pressure decreases at a rate of 6.5 psi per 100 psi decrease in the inlet pressure (see Supply Pressure Effect specification).

CONTROL ENGINEERING DATA

Control Engineering Data (CED) provides a configuration breakdown by the standard 15-digit model number of the regulator.

Characters 1-5: HP635 (Pressure Regulator Model)

Character 6: Materials of construction

Body / Bonnet / Valve Trim

H = 316SS / Nickel Plated Brass / 316SS – 35Ra finish

3 = 316SS / Nickel Plated Brass / 316SS – 15Ra finish

B = Brass / Nickel Plated Brass / 316SS – 35Ra finish

Characters 7&8:

11 (316L diaphragm, PCTFE valve seat)

Character 9: R (Non-Relieving diaphragm)

Characters 10 & 11: Inlet and Outlet Port

6T = 1/2" x 0.049 Wall Tube Stubs

N3 = 1/2" NPT Female

Note: A 40 micron filter screen is installed in the Inlet port for option N3 only.

Character 12: Mounting

N = Line Mount Only

P = Panel Mount Option (2-Nut)

Character 13: Cleaning

A = Standard Cleaning (ES8A 01 294)

B = Oxygen Cleaning (ES8A 01 297)

C = Customer Specified Cleaning

NOTE: Materials of construction and cleaning specifications are the user's responsibility.

Character 14: B (standard control knob)

Character 15: Maximum Control Range

A = 25 psig (0.17 MPa)

B = 50 psig (0.34 MPa)

C = 100 psig (0.69 MPa)

D = 150 psig (1.04 MPa)

L = 200 psig (1.38 MPa)

OPERATION IN SERVICE

Open upstream controls to provide the regulator supply pressure. To increase the output set pressure, rotate the control knob clockwise. To decrease the output set pressure, rotate the control knob counterclockwise.

When the system is being shut down, it is an established safety practice to reduce the output pressure under flow then shut off the supply pressure to the regulator. After all pressure is relieved from the system, back out the control knob until there is no spring resistance felt on the control knob. This will assure that no output pressure will be generated when the supply pressure to the regulator resumes, the next time the system is used.

This regulator is equipped with an adjustment retention device to prevent control knob removal when the output pressure is adjusted below zero output set pressure.

NOTE: *The HP635 is a non-relieving regulator.* To reduce the downstream pressure, the system must be flowing while the control knob is rotated counterclockwise.

NOTE: The downstream pressure will change as the flow changes. As the flow increases, the delivery pressure will decrease. See the HP635 representative flow performance graphs of this product below.

NOTE: The outlet set pressure will change as the inlet pressure changes. The output set pressure will increase as the supply pressure decreases at a rate of 6 to 7 psi per 100 psi decrease in the inlet pressure.

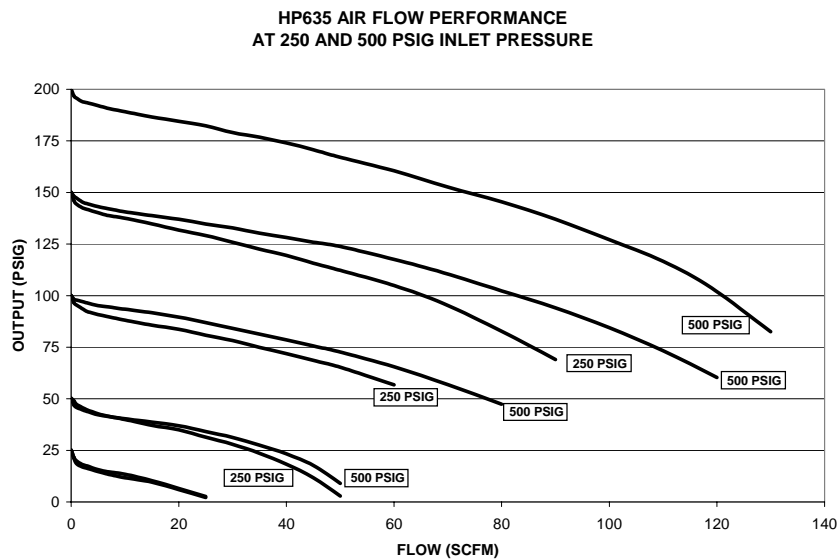

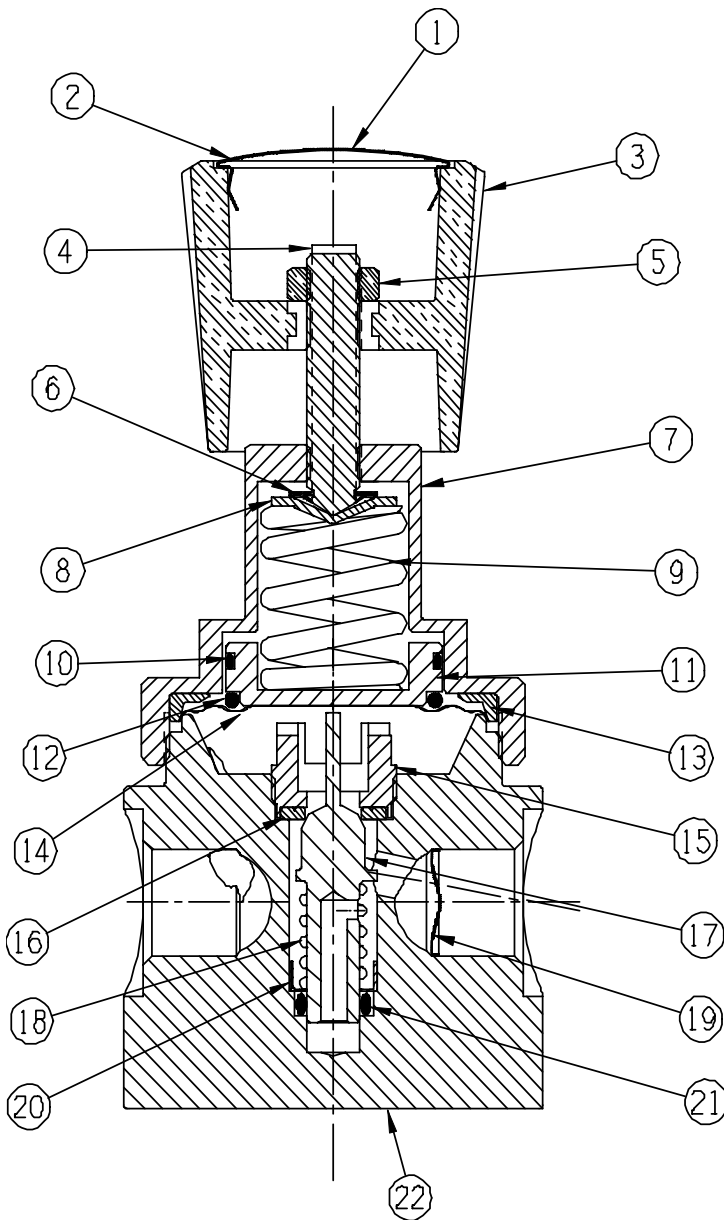

Item	Description	Part Number	Qty
1	LABEL	96601PO	1
2	HOLE PLUG	96401SN	1
3	HAND KNOB	71450PP	1
4	ADJUSTMENT SCREW	71070S3	1
5	JAM NUT	75850NB	1
6	PALNUT	75855CZ	1
7	BONNET (STD) BONNET (FOR PANEL MOUNT)	71263B3NE 71264B3NE	1
8	SPRING BUTTON	71550S6	1
9	RANGE SPRING 25 PSI RANGE 50 PSI RANGE 100 PSI RANGE 150 PSI RANGE 200 PSI RANGE	72150CS 72151CS 72155C9 72140CE 72140CE	1
10	O-RING	502050BN	1
11	BACKUP PLATE	72963B3	1
12	O-RING	502049TF	1
13	SEAL RING	71860S6	1
14	DIAPHRAGM	74162S6	1
15	SEAT GLAND	73561S6	1
16	SEAT, VALVE	73661KF	1
17	VALVE PLUG	73163S6	1
18	VALVE SPRING	72522S2	1
19	FILTER SCREEN	73863S6	1 *
20	SPRING POSITIONER	73460S6	1
21	O-RING	502048TF	1
22	BODY 1/2" NPT, 35 Ra 316 STAINLESS 1/2" NPT, 35 Ra BRASS 1/2" TUBE STUB 316 STAINLESS	70656S6 70656B3 70655S6	1
-	PANEL MOUNT NUT	76201SN	2

NOTES:

- Filter screen 73863S6 is not used with tube stub (6T) type body.
- For 15 Ra option (material code 3 in CED) add suffix EP to the part number for items 15, 17, 20 and 22.
- 1 or 2 panel mount nuts may be used with this item.
- For special models (non CED codeable), consult factory for parts list.

TROUBLESHOOTING GUIDE

Symptom: Outlet pressure continues to rise after flow ceases.

Potential Cause: Valve seat leakage

Repair: Disassemble and clean regulator components. Install new valve seat and filter screen (if applicable). Reassemble.

Symptom: External leakage

Potential Cause: Diaphragm to body joint seal leakage.

Repair: Disassemble. Inspect regulator body where diaphragm seals. Replace diaphragm.

Symptom: Outlet pressure cannot be adjusted to maximum control range.

Potential Causes:

1. Control knob positive stop adjustment.
2. Flow induced droop.

Repair:

1. Adjust positive stop of control knob.
2. See note below operating instructions and flow curves for explanation – a higher range regulator may be required.

Symptom: Noisy operation.

Potential Causes:

1. Turbulence in adjacent piping.
2. O-rings are worn.

Repair:

1. Insure that there are no elbows, line tees or other turbulence creating piping directly upstream or downstream of the pressure regulator.
2. Disassemble and replace o-rings.

REPAIR AND MAINTENANCE

WARNING: To prevent equipment damage or injury, insure that all system pressure is relieved and the supply valve for this regulator is secured in the off position.

CAUTION: Cleanliness is critical to successful maintenance and repair of this product. Perform all repair work in a clean environment, with clean tools, and the correct materials and supplies.

Tools and Materials Required:

A vise, or other suitable fixture, to secure the regulator.

A small flat screwdriver and / or sharp instrument (for removal of the control knob hole plug, if required).

9/16" deep socket (for adjustment screw jam nut).

3/4" deep socket (for seat gland)

A 1 7/8" Crowfoot wrench (for bonnet).

Torque Wrenches

Assembly Lubricant (DuPont Krytox 240AC or Christo-Lube MGC-111).

Clean, lint free wipes and swabs.

DISASSEMBLY

1. Secure the pressure regulator.
2. Remove the control knob hole plug (2).
3. Turn control knob (3) counterclockwise until the range spring (9) is unloaded.
4. If the adjustment screw (4) requires removal, secure the control knob (3) and unscrew the jam nut (5), then unscrew the control knob (3) from the adjustment screw (4).
5. Loosen the bonnet (7) with the crowfoot wrench.
6. Remove the o-ring (12) from the top of the diaphragm (14).
7. Remove the diaphragm backup (11), range spring (9), and spring button (8) from the bonnet. If the adjustment screw (4) requires replacement, unscrew the adjustment screw (4) and Palnut (6) from the bonnet (7) inward with a slotted screwdriver.
8. Carefully remove the rubber o-ring (10) from the backup plate (11) with a small screwdriver or other suitable instrument.
9. Remove the seal ring (13) if the bonnet (7) or seal ring requires replacement.
10. Remove the seat gland (15) by unscrewing it counterclockwise with a 3/4" socket.
11. Carefully remove the valve seat (16) from the seat gland (15) by picking it out with a sharp instrument.
12. Remove the valve plug (17), plug spring (18), and spring positioner (20) by carefully lifting them out of the valve plug bore of the regulator body (22).
13. Remove the Teflon o-ring (21) from the regulator body (22) by carefully picking it out with a sharp instrument.
14. Remove the filter screen (19) as applicable.

ASSEMBLY

1. Replace worn or damaged components with new components.
2. Clean and inspect components for reuse. Sealing surfaces must be smooth and free of wear or scratches.
3. Install a new filter screen (19) into the "IN" port of the regulator body, if applicable. The screen is oriented with the cupped / bulged side facing out of the port.
4. Install a new Teflon o-ring (21) in the bore of the regulator body (22).
5. Install the valve plug (18), plug spring (18), and spring positioner (20) by carefully placing them into the valve plug bore of the regulator body (22).

6. Install a new valve seat (16) in the seat gland (15) so the face grooved side faces out.
7. Sparingly apply lubricant to the seat gland threads in the regulator body (22) with a clean swab.
8. Thread the seat / seat gland (16 and 15) into the regulator body (22). Tighten to 225 +/- 15 in-lb.
9. The main valve can be tested at this point by connecting the inlet port of the regulator to a supply of test pressure (100 psig or less) and checking the valve / seat interface for leakage.
10. Lubricate the adjustment screw (4) with grease (see tools and materials required for suggested lubricant), and thread it into the regulator bonnet (7).
11. Install Palnut (6) over the conical end of the adjustment screw (4) with a socket and a light hammer blow.
12. Lubricate seal ring (13) and the large internal bonnet threads. Place the seal ring (13) in the bonnet (7) as shown.
13. Lubricate and install the rubber o-ring (10) on the backup plate (11).
14. Invert the bonnet (7). Dab some lubricant in the spring button (8) and set it on the adjustment screw (4). Place the range spring (9) on the spring button (8) in the bonnet (7). Assemble the backup plate (11) and o-ring (10) in the bonnet as shown.
15. Place the diaphragm (14) on the regulator as shown.
16. Place the o-ring (12) on the diaphragm.
17. Place the bonnet (7) and other components on the regulator and thread the bonnet (7) onto the regulator body (22). Tighten to 100 ft-lb with the crowfoot wrench.
18. The regulator can be bench tested at this point, using a screwdriver to temporarily adjust the output pressure.
19. If the regulator is to be panel mounted, install the regulator into the panel with the panel mounting nuts.
20. Install the control knob (3), and adjust the maximum output pressure as described in the installation portion of this document.
21. Replace the hole plug (2) and the increase / decrease label (1) in the control knob.

This page is intentionally left blank