



105 Commerce Way  
 Westminster, SC 29693  
 Tel: (864) 647-9521  
 Fax: (864) 647-9568

**WARNING**

Conoflow's products are designed and manufactured using materials and workmanship required to meet all applicable standards. The use of these products should be confined to services specified and/or recommended in the Conoflow catalogs, instructions, or by Conoflow application engineers.

To avoid personal injury or equipment damage resulting from misuse or misapplication of a product, it is necessary to select the proper materials of construction and pressure-temperature ratings which are consistent with performance requirements.

## INSTRUCTION AND MAINTENANCE MANUAL HP300 HIGH PRESSURE REGULATOR

**CAUTION:** These instructions should be read and understood prior to installation, use, or maintenance.

desired level of cleaning. Cost will be advised prior to performing the cleaning operation.

### GENERAL PRODUCT OVERVIEW

The HP300 Regulator is a self-contained, spring loaded pressure reducing regulator. This unit is a piston sensed, self-relieving regulator which allows a pressure setting reduction in a closed system by relieving downstream pressure through the regulator.

A Vespel main valve seat is utilized for bubble tight shut off in dead-ended applications. Control pressure ranges can be changed without removing the regulator from the process line.

**CAUTION:** Maximum Supply Pressure  
 Stainless Steel 10,000 PSIG (69 MPa)  
 Brass 6,000 PSIG (41.4 MPa)  
 Maximum supply pressure can be derated based on internal material selections. See notes in CED code (page 4).

**WARNING:** The HP300 is a relieving regulator and should not be used with hazardous gases.

### MATERIALS OF CONSTRUCTIONS

When a relieving style sensor is used, hazardous or corrosive fluids should not be used. When the non-relieving sensor is used the HP300 will operate with any fluid (liquid or gas) which is compatible with the materials of construction. To identify the materials of construction, refer to Control Engineering Data contained on page 4.

A 20 micron filter is installed in the regulator to stop random contamination resulting from installation. An auxiliary filter is recommended for all but the cleanest fluid. Gaseous fluid must be free of excessive moisture to prevent internal icing or condensation during operation.

Body	Brass/303SS/N.A.C.E 316SS
Bonnet	Brass/Plated Brass
Main Valve Seat	Vespel (Kel-F Optional)
Relief Valve Seat	Kel-F
Sensors and Trim	300 Stainless Steel
Seals	Buna-N / Teflon (Viton Optional)

### OUTLET PRESSURE RANGES

OPTION CODE	RANGE
"F"	0-500 PSIG (3.45 MPa)
"G"	0-800 PSIG (5.52 MPa)
"H"	0-1500 PSIG (10.35 MPa)
"J"	0-2500 PSIG (17.25 MPa)
"K"	0-4000 PSIG (27.60 MPa)
"L"	0-6000 PSIG (41.40 MPa)

### REGULATOR CLEANING

The HP300 Series High Pressure Regulator is cleaned to ITT Conoflow Specification ES8A 01 294.

### PORTING CONFIGURATIONS

There are four (4) 1/4" NPTF connection on the HP300. The supply connection port is labeled "IN" and the supply gauge port is labeled "HI". The outlet port is labeled "OUT" and the outlet gauge port is labeled "LOW". Care should be exercised when installing the high pressure line to assure it is connected to the inlet ("IN") port, otherwise the regulator will not function properly. See figure 1 on page 5 for port identification drawing.

### OXYGEN SERVICE

Specification of materials in regulators used for oxygen service is the USER'S RESPONSIBILITY. Cleaning for oxygen service (per ES8A 01 297) to 3500 PSIG (24.20 MPa) is supplied by ITT Conoflow at no additional cost. For special cleaning requirements, the customer must supply specifications for the

Teflon thread tape is the preferred thread sealant when the regulator is installed.

## INSTALLATION

The HP300 can be line or panel bracket mounted. For line mounted applications, refer to porting configurations for proper orientation of ports.

Panel bracket mounting can be achieved using the two 1/4-20 threaded mounting holes in the bracket. These threaded mounting holes are spaced 2.80" (71.1 mm) apart.

## PRINCIPLE OF OPERATION

Turning the control knob clockwise will increase the force on the range spring and in turn the outlet set pressure. Conversely, turning the control knob counterclockwise will decrease the force on the range spring and decrease the outlet set pressure. In equilibrium, the force exerted by the range spring is balanced by the outlet pressure.

An unbalance between the outlet pressure and the set pressure causes a corresponding reaction on the sensor and valve. If the outlet pressure rises above the set pressure, the piston sensor will lift allowing the main valve to seat. This action causes the relief valve to open relieving the excess pressure to atmosphere until equilibrium is reached.

If the outlet pressure falls below the set pressure, the range spring will push the sensor down and unseat the main valve. This allows supply pressure to flow through the main valve to the downstream port increasing output pressure. At equilibrium, the valve plug assumes a position which supplies the required flow while maintaining the outlet pressure at the set pressure. See figure 2 on page 5 for labeled assembly.

## MAINTENANCE

All regulators require scheduled maintenance to remove deposits left by the media and to replace parts worn or damaged as a result of use. Annual maintenance is recommended when the regulator is used under normal conditions. More frequent maintenance may be required due to the condition, cleanliness and/or corrosiveness of the media.

## TOOLS REQUIRED

1/4" Open end wrench ("T" handle disassembly)  
3/16" Wide, flat blade screwdriver (relief adjustment screw)  
5/16" Wide, flat blade screwdriver (spring button screw)  
1/2" Open end wrench (spring base on sensor assembly)  
1/2" Wide, narrow blade screwdriver (sensor)  
1/2" Socket (main valve gland)  
3/4" Wide, narrow ground screwdriver (valve body)  
1-3/4" Open end or crowfoot wrench (for the bonnet)  
Pin Vise (remove sensor relief valve seat)  
Pliers (to remove sensor assembly)  
Retaining ring pliers (handknob retaining ring)  
Tweezers (to remove connector pin from the main valve gland)  
Other possible tools would be a vise, a clean lint-free cloth, and a torque wrench.

### CAUTION: MAINTENANCE

It is recommended that maintenance be performed by a person experienced in the operation and repair of high pressure regulators.

Maintenance of this unit is best performed by gripping a protruding end of a pipe fitting installed into the regulator body.

**WARNING:** Bleed System Pressure Prior to Removing Regulator for Servicing.

## MAINTENANCE PROCEDURE

1. Adjust the handwheel to the full counterclockwise position. Remove the hole plug and with retaining ring pliers remove the retaining ring. Grip the handwheel firmly and pull upward until free.
2. Unscrew the bonnet using 1-3/4" open end or crowfoot wrench. This will come off as an assembly containing the bonnet, thrust bearing assembly, spring button screw, spring button, adjusting stem, stem rod, stem screw, and stem spring. Note that the rod will drop free when the bonnet is unscrewed. Lift off the range spring.
3. To service components in the bonnet assembly, remove spring button screw. The adjusting stem, thrust bearing assembly, and spring button will drop out. Unthread the stem screw and remove the stem spring.
4. To remove the sensor assembly grip the spring base with pliers and pull upward until assembly is free. Lift out the sensor assembly backup ring and the sensor assembly O-ring.
5. Lift out the connector pin and then remove seat gland and main valve seat using 1/2" socket.
6. Remove the main valve body as an assembly using 3/4" screw driver.
7. With the main valve assembly removed from the body hold firmly in hand and unthread the filter. The main valve plug and main valve spring will drop out. Remove and inspect the valve body backup ring and the valve body O-ring.
8. To disassemble the sensor assembly, grip the sensor and unthread the spring base using a 1/2" open end wrench. When the spring base is removed, the vent seat will be freed. With your thumb, firmly push sensor until it is freed from the sensor ring. Remove the O-ring and backup ring. The vent plug and spring can be removed for inspection.

NOTE: See figure 3 on page 5 for exploded view.

### THE REGULATOR IS RE-ASSEMBLED IN THE REVERSE ORDER OF DISASSEMBLY, OBSERVING THE FOLLOWING PRECAUTIONS:

1. Inspect all component parts and replace those worn or damaged with ITT Conoflow replacement parts. Always replace the valve seats if they have been removed.
2. All component parts should be cleaned to the cleanliness level required for safe operation with the media used. All parts in the flow stream must be free of particles which could prevent proper seating of the main valve.

## BONNET ASSEMBLY

- A. Lubricate the left hand threads of the adjusting stem with Krytox grease. Thread the spring button onto the threads, large end first. Place a well-greased thrust bearing assembly on the adjusting stem with the shield away from the spring button.
- B. Slide the adjusting stem, spring button, and thrust bearing assembly into the bonnet until the end comes through the center hole in the end of the bonnet. Rotate the adjusting stem and spring button until the 1/4-20 threads in the spring button are aligned with the slot in the side of the bonnet. Using a 5/16" flat blade screwdriver, screw the spring button screw into the spring button and tighten to 30 in. lbs.
- C. Press the handwheel onto adjusting screw until the groove is cleared. Install the wavy retaining ring onto the adjusting stem in the groove provided. Set the bonnet assembly aside.

## SENSOR ASSEMBLY

### Sensor Assembly for 0-500/800/1500 PSIG Ranges (No Backup Ring)

- A. Lubricate the O-ring with Krytox. Also lubricate the groove in the sensor ring. Place the O-ring in the groove in the sensor ring. Secure the O-ring by installing the sensor. When installing the sensor, insert the smaller diameter end of the sensor into the sensor ring until it seats firmly.

### Sensor Assembly for All Other Pressure Ranges

- A. Lubricate the O-ring and backup ring with Krytox grease. Install the backup ring in the sensor ring so the flat side is against the shoulder. Place the O-ring in the sensor ring against the backup ring. Secure the O-ring and backup ring by installing the sensor. When installing the sensor, insert the smaller diameter end of the sensor into the sensor ring until it seats firmly.

## ALL SENSOR ASSEMBLIES

- A. – Relieve to Atmosphere models: Insert the spring in the sensor. Place the relief plug on the spring so the shoulder is against the spring. Place the relief seat on the relief plug with the small countersunk side towards the relief plug. Snap the relief seat into the counterbore of the sensor.
- B. Screw the spring base on the threads of the sensor being sure the relief seat correctly engages the counterbore in the sensor. Torque the spring base to 75 in.lbs.

## REGULATOR ASSEMBLY – MAIN VALVE ASSEMBLY

1. Holding the main valve body, with the large groove neck facing down, insert the main valve plug. Place the main valve plug spring over the main valve plug and thread the filter until it seats.
2. Install the main valve body backup ring and the main valve body O-ring in the groove on the main valve body. Lubricate both component parts and the groove with Krytox grease prior to assembly.
3. Thread the main valve body assembly into the body hand tight. With the 3/4" wide, narrow ground screwdriver, thread the main valve body until it is flush with the flat surface on the counterbore face of the body.
4. Snap the main valve seat into the seat gland. For Kel-F seats, install the countersink away from the seat gland. Vespel seats do not have this countersink. Lubricate the threads on the seat gland with Krytox grease and thread into the main valve body until flush. A 1/2" socket is needed to tighten the main valve body. Tighten to 75 in. lbs.
5. Insert the connector pin in the seat gland with the square end pointing up.

## REGULATOR ASSEMBLY

1. Lubricate the sensor assembly backup ring and the sensor assembly O-ring with Krytox grease. Install the O-ring in the counterbore in the body and place the backup ring on top.
2. Place the sensor assembly, with the spring base facing up, in the body until it engages the O-ring and backup ring.
3. Place the range spring on the spring base of the sensor assembly. Install the bonnet assembly and torque to 50 ft. lbs.
4. Relieve to Atmosphere Models: Slip the stem rod into the adjusting stem and let it drop-down to the vent seat Slide the stem spring into the adjusting stem and thread the stem screw. Do not tighten the stem screw, only start the threads.
5. Relieve to Atmosphere Models: Connect an air supply to the inlet port of the regulator and slowly increase the outlet pressure to 100 PSIG. SLOWLY tighten the stem screw until the relief valve opens and flow is heard. Back out the stem screw just past the point where the relief valve re-seals.
6. Install the handwheel's hole plug.

Prior to installation, the regulator should be connected to a pressure source with a media compatible with the use of the regulator, and should be pressurized to check for internal and external leakage and operating characteristics.

NOTE: See figure 2 on page 5 for assembled view.

## Regulator Model Breakdown (CED Code)

Control Engineering Data is intended to provide a single source from which one can determine, in detail, the full scope of the product line. In addition to the materials of construction, diaphragm and elastomer selection, it also provides all necessary data regarding adjustment option and range selections. Control Engineering Data also provides a means of communicating by way of a code number which is fully descriptive in product selection. All catalog numbers received must contain fifteen (15) characters.

1 through 5	HP300	Pressure reducing Regulator, Piston Type (High Outlet)
		<i>Body / Bonnet / Trim</i>
6	B S R	Brass / Brass / 300 Stainless Steel 303 Stainless Steel / Nickel Plated Brass / 300 Stainless N.A.C.E 316SS / Nickel Plated Brass / 316 Stainless Steel (See Notes 1 & 2)
		<i>Main Valve Seat / Vent Valve Seat / Backup Ring / O-Ring / Notes</i>
7 through 8	11 12 13 14 15 16 17 18	Vespel / Kel-F / Buna-N or Teflon / Buna-N / - Kel-F / Kel-F / Buna-N or Teflon / Buna-N / 4 Vespel / Kel-F / Teflon / Viton / - Kel-F / Kel-F / Teflon / Viton / 4 Vespel / None / Buna-N or Teflon / Buna-N / 3 Kel-F / None / Buna-N or Teflon / Buna-N / 3 & 4 Vespel / None / Teflon / Viton / 3 Kel-F / None / Teflon / Viton / 3 & 4
9	N V W	Non-relieving (Optional) Relieve to atmosphere Non-relieving (No Filter) (Optional) (See Note 5)
10 through 11	61	1/4" NPT Connections (See Note 6)
12	P S	Panel Mounting Bracket (Optional) Plain bonnet (No threads) (Standard)
13	A B C	Regulator is cleaned to ITT Conoflow Specification ES8A 01 294 Oxygen Cleaning: Specification of materials in regulators used for oxygen service is the user's responsibility. Cleaning for oxygen service to 3500 PSIG (24.20 MPa) is supplied by ITT Conoflow at no additional cost. Customer Specified Cleaning: Customer to specify the desired level of cleanliness. ITT Conoflow will advise cost prior to performing cleaning operation. Specification of materials is the USER'S RESPONSIBILITY.
14	B T	Handwheel "T" bar handle (Optional)
15	F G H J K L	0-500 PSI (0-3.45 MPa) 0-800 PSI (0-5.52 MPa) 0-1500 PSI (0-10.35 MPa) 0-2500 PSI (0-17.25 MPa) 0-4000 PSI (0-27.60 MPa) 0-6000 PSI (0-41.40 MPa)

**NOTES:**

1. National Association of Corrosion Engineers.
2. Maximum supply pressure must not exceed the maximum pressure rating of the supply connection and supply gauge connection.
3. These options are offered for non-relieving units.
4. The options cannot be used for 10,000 PSIG (69.00 MPa) applications. Use Vespel main valve seats for applications above 6000 PSIG (41.10 MPa).
5. Option W is 120 mesh screen.
6. All gauge port connections are 1/4" NPT.

# CONNECTION IDENTIFICATION AND TYPICAL GEOMETRY

## HP300B11V61SABF CONFIGURATION SHOWN

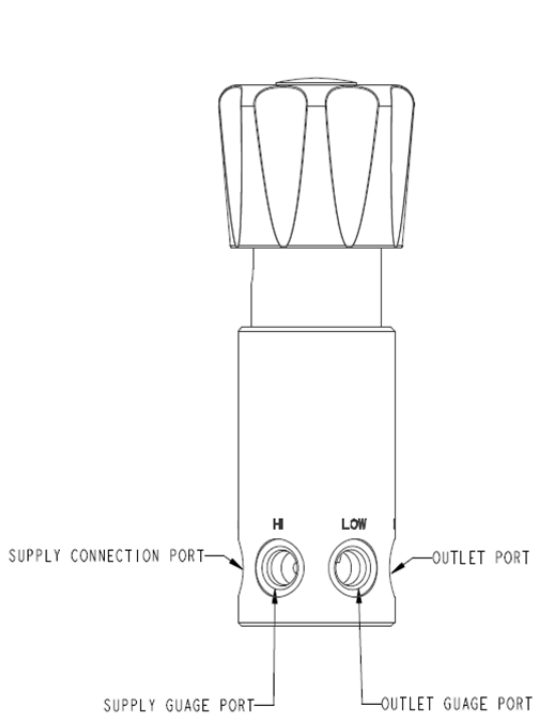

FIGURE 1: HP300 Regulator Port Locations

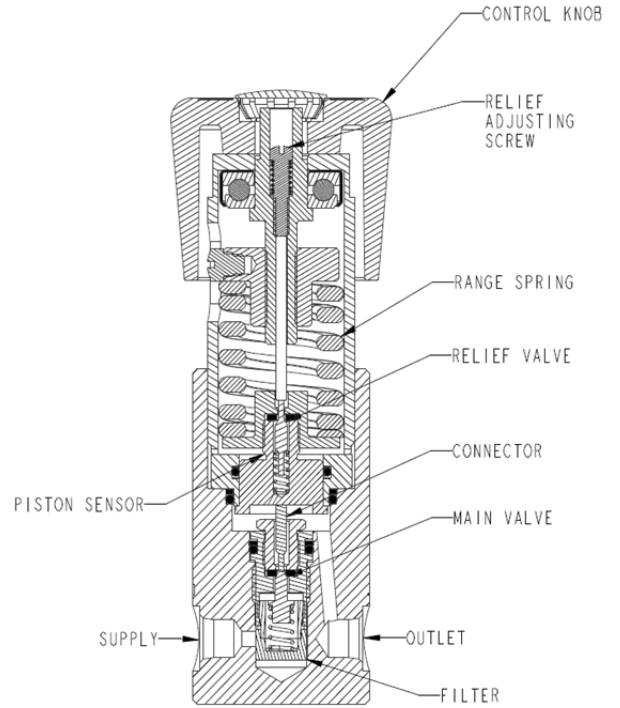

FIGURE 2: Labeled Section View of HP300 Regulator

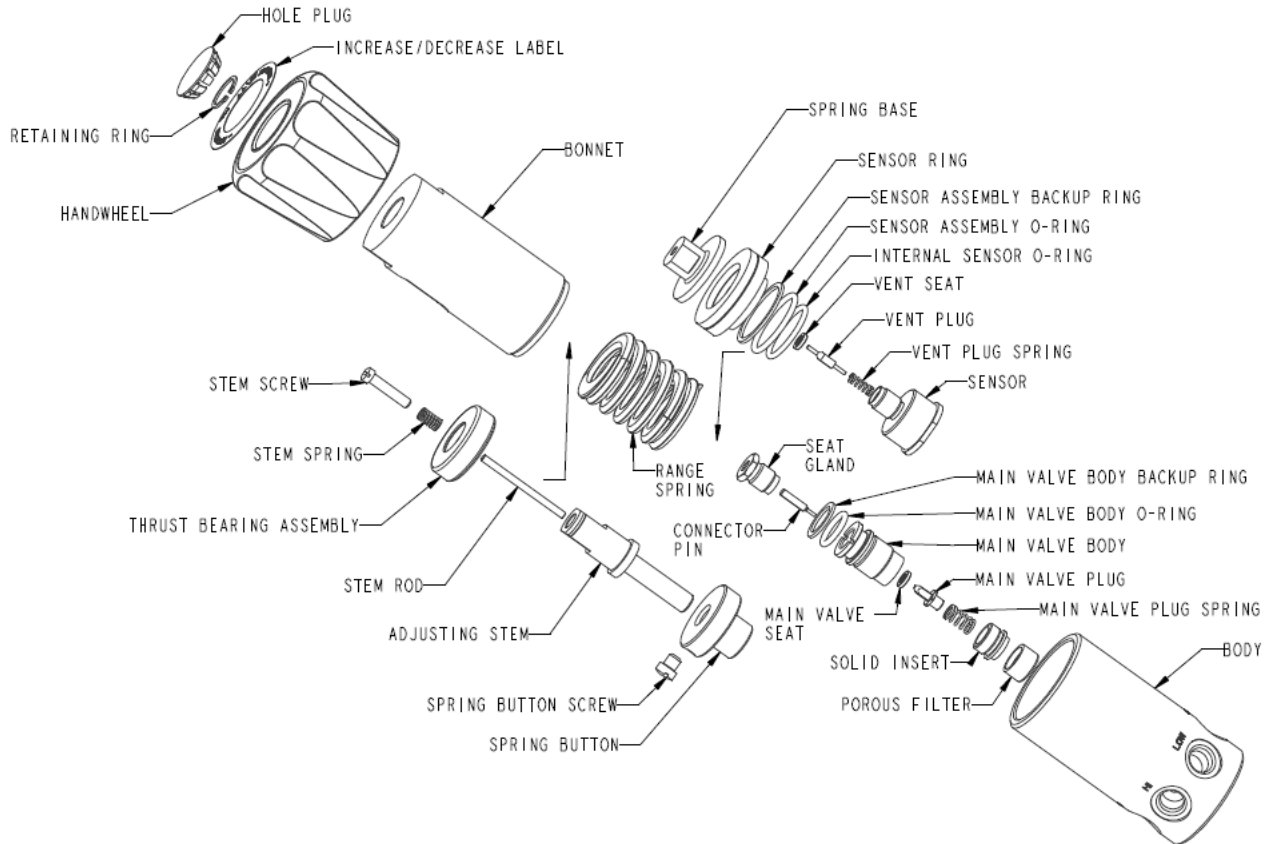

FIGURE 3: Exploded View of HP300 Regulator

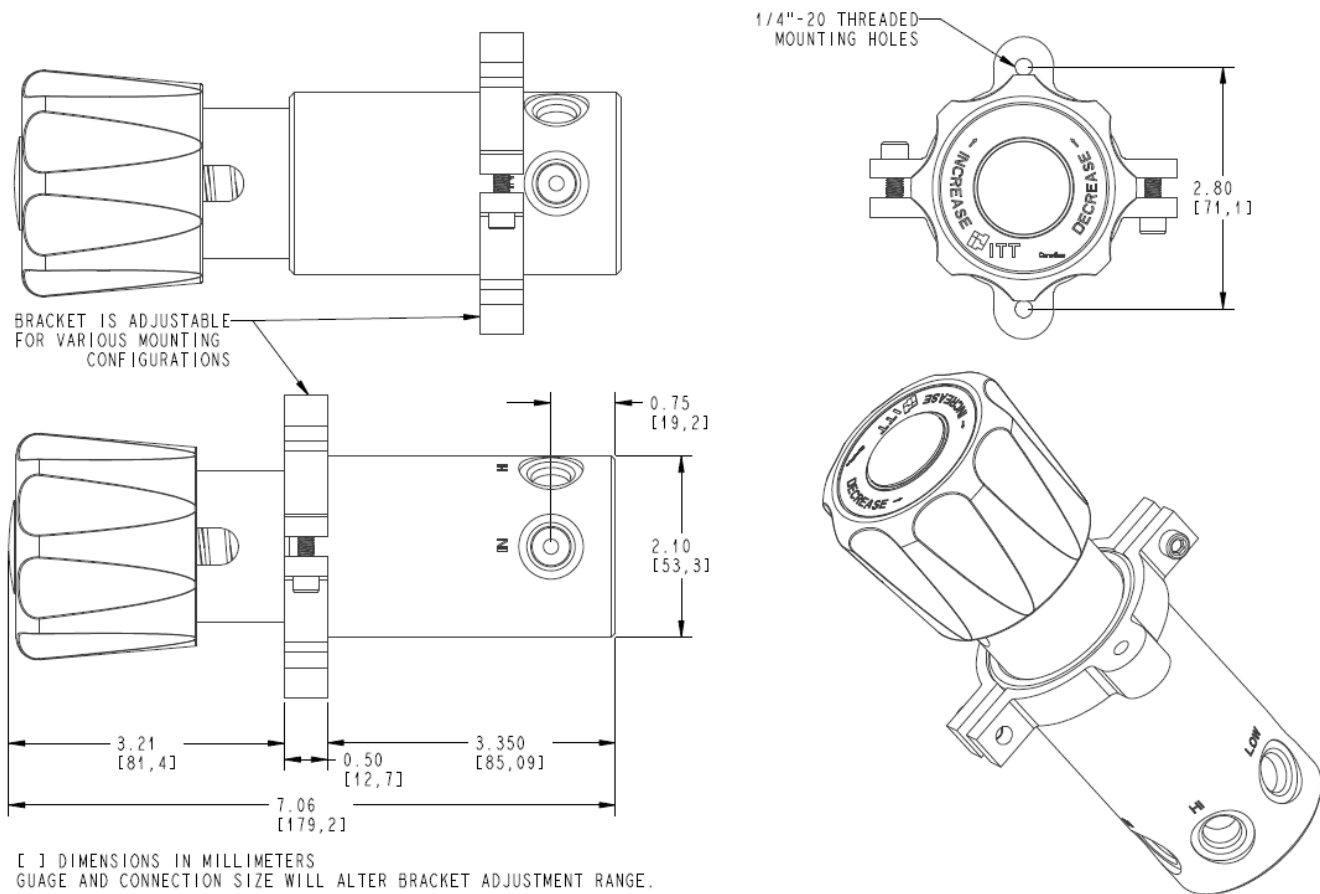

FIGURE 4: HP300 Regulator Shown with Optional Panel Mounting Bracket (HP300B11V61PABJ configuration shown)

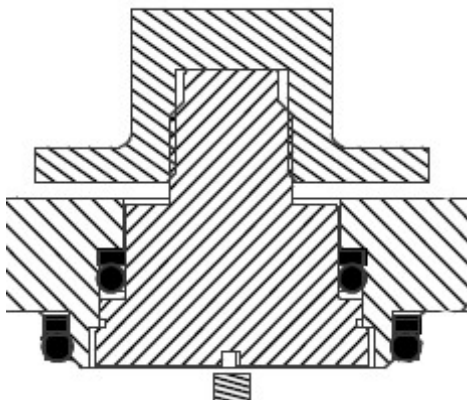

FIGURE 5: Sensor Assembly without Relief Valve

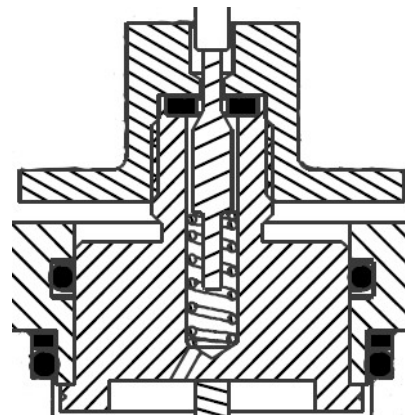

FIGURE 6: Sensor Assembly with Relief Valve

## **TROUBLESHOOTING**

When performing necessary corrective action in the following operations, refer to the **MAINTENANCE** section for the necessary procedure.

### **PROBLEM:**

The regulated pressure continues to increase after lock-up and without change in the control mechanism position.

### **POSSIBLE CAUSE:**

The main valve seat needs replacement; follow maintenance procedure and regulator assembly.

The sensor assembly needs cleaning and the seals need to be replaced; follow maintenance procedure and sensor disassembly and reassembly.

### **PROBLEM:**

Continuous leakage through the bonnet, with the outlet pressure on the regulator.

### **POSSIBLE CAUSE:**

Vent valve needs adjustment.

Vent valve seat needs replacement.

Sensor O-ring is worn, leaking, and needs to be replaced.

### **PROBLEM:**

Regulated pressure drops off sharply when the flow is within the regulator's capabilities.

### **POSSIBLE CAUSE:**

Check the inlet filter and clean if necessary.

Main valve seat needs replacement; follow maintenance procedure and regulator assembly.

***An ITT Company***