

Different Seat Options Provide Precise Pressure Control

Conoflow Diaphragm Application Story

Conoflow's low pressure regulators are provided with three different diaphragm seat options as mentioned in our last Application Story. These low pressure regulators are also equipped with two different styles of nozzle assemblies which work in conjunction with the diaphragm assemblies in which the supply air or process media passes through.



The standard low pressure nozzle assembly is equipped with a metal to metal seating surface. This assembly will allow leakage of the supply pressure to pass by the seat when the nozzle is in the closed position at a rate of 100 cc/minute or less. This keeps the regulator in a dynamic state lessening the pressure drop when there is a demand for flow.

The Nozzle and Diaphragm Assemblies work together to perform the following function. With supply pressure applied to the regulator any adjustment of the range spring causes a corresponding reaction in the nozzle and diaphragm assemblies. When the adjusted output pressure rises above the set pressure, the diaphragm seat is lifted off the nozzle plug. When this occurs the excess pressure is vented to the atmosphere until equilibrium is obtained. If the downstream output pressure drops below the set pressure the force of the range spring,

pushing down on the diaphragm assembly opens the nozzle assembly. The unseating of the nozzle plug allows supply pressure to flow through the nozzle to the downstream port increasing the output pressure. As the output pressure increases a balance between the force of the range spring, nozzle and diaphragm assemblies will occur.

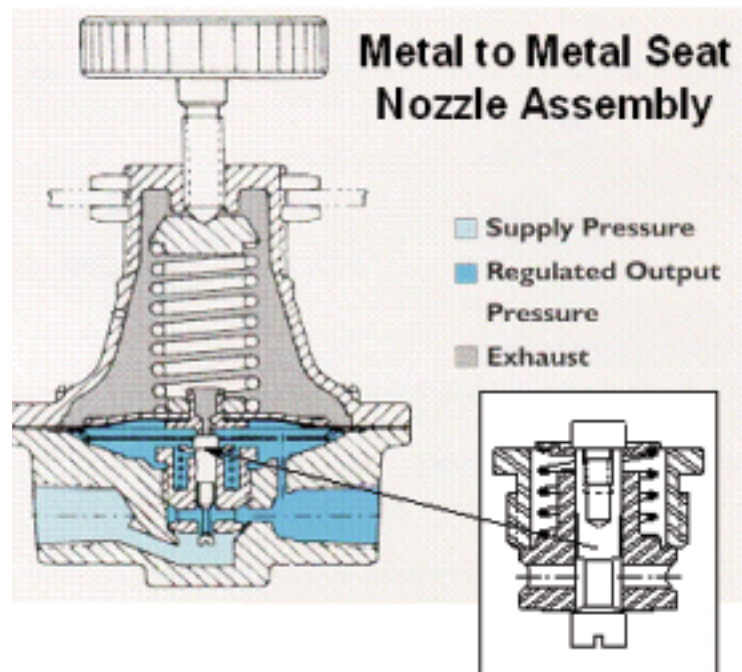

Different Seat Options Provide Precise Pressure Control

Conoflow Diaphragm Application Story

When application require positive shutoff of process media the molded rubber soft seated nozzle assembly may be required. This nozzle assembly is equipped with molded rubber seats on both the top and bottom of the nozzle assembly when supplied with a relieving style diaphragm assembly. When the No Bleed No Relief diaphragm assembly is selected the rubber molded seat is supplied on the bottom of the nozzle assembly only.

When the regulated downstream pressure is not being consumed the bottom molded rubber seat will not allow supply air or process media to flow downstream or vent to atmosphere. The top rubber molded seat allows for minimum air consumption under flow conditions.

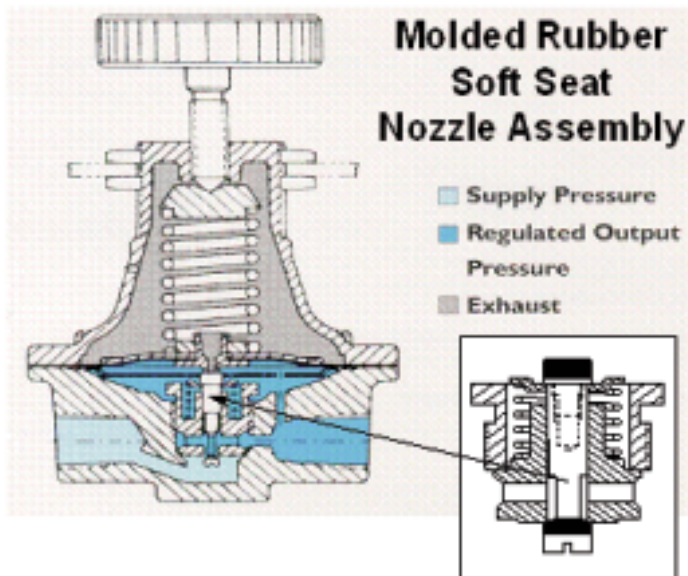

Diaphragm Seat Option: No Bleed-No Relief (Non-Relieving)

This type of diaphragm seat option is best suited for applications where the regulated process media is under constantly flowing conditions or when liquids or harmful gases are present in the process media.

Diaphragm Seat Option: Relieving (With Relief-No Bleed)

This type of diaphragm seat option is used to allow relieving (venting or exhausting of process media to atmosphere that is in excess of the regulator's set point.

Diaphragm Seat Option: Constant Bleed (With Bleed and Relief)

This type of diaphragm seat option is used to increase responsiveness and stability. This option is offered on the manual loading regulators only.